

Type SGS-02-11-S

basic @ level

Limit switch for the food industry

Basic Features

- ▶ One limit switch for watery and oily media
- ▶ Two steady adjusted switch on /off treshold, free adjustable with software (no two units required) Standard: watery media
- ▶ welding sleeve-system with modular process conections
- ▶ Aseptic measuring point
- ▶ Wetting parts made of peek
- ▶ Display of the switching state via brighth TOP LED illuminated ring of PA-GF20
- ▶ Very high meauring dynamic
- ▶ Partly moulded
- ▶ EHEDG certified, FDA-conformal

Technical Features

- ▶ High-grade steel connecting head
Material No. 1.4404 (316L)
- ▶ Connection: M12 plug (1.4301)
- ▶ Thread G 1/2" elastomerfree sealing system
- ▶ Sensor heads made of Peek (HPC-Tip)
- ▶ CIP-/SIP cleaning 0... + 150°C (30 min)
ambient temperature 40°C
- ▶ Supply Voltage 12...32 VDC
- ▶ Output signal PNP (standard), NPN or Push-Pull switchable/ NC, NO switchable
- ▶ Power up delay < 0,3s
- ▶ Response time 0,2s
- ▶ Ambient temperature -10...+70°C
- ▶ Medium temperature durable 0...+100°C
- ▶ Storage temperature -20...+70°C
- ▶ Working pressure 10 bar bar
(Higher pressures on request)
- ▶ Protection class IP68 / 69K
- ▶ Torque max. 20 Nm
- ▶ Permissible Load: 100mA

Favoured fields of application are e.g:

The smw is a micro-processor controlled limit switch for liquids or paste-like and adhesive medias.

- ▶ Low- / high alarm in containers
- ▶ Media registration in pipes as pump protection
- ▶ Fill level detection of liquids in containers + pipes



Approvals

EHEDG, Hygienic Peek Connect G 1/2" (HPC)
Certificate Number 21/2017

Certificate only valid in combination with an EHEDG process tip (HPC tip) and process adapter (HPC sleeve). Permissible process adapters see data sheet
"Process adaptation"



Visualization via PC-USB interface Software incl for readout the SGS

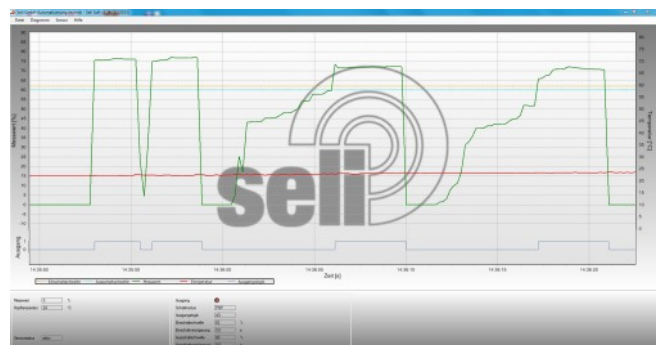



Type SGS-02-11-S

basic @ level

Parameterization (optional accessories)

For parameterization, both the PC USB interface STPA-M12 and the programming adapter ST-M12-Y-AD is required.

ST-PA-M12

PC-USB-Interface incl. the Software for readout and parameterize.

ST-M12-Y-AD

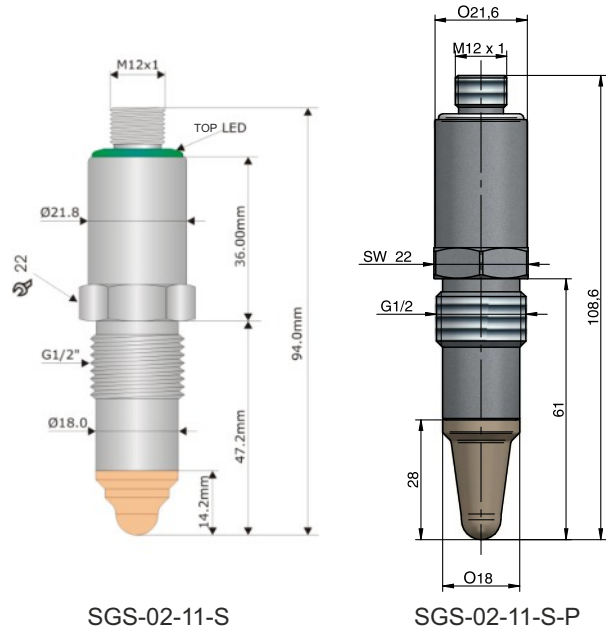
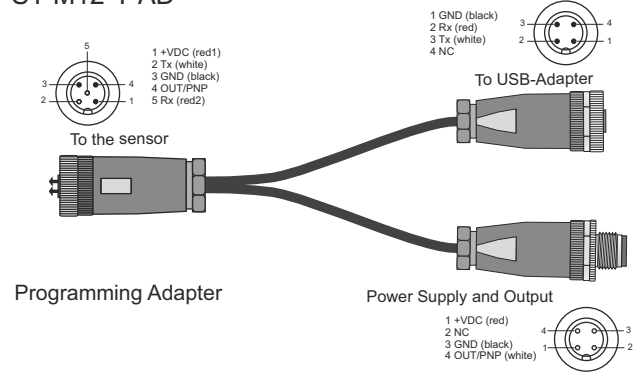

Notice

Suitable for applications with predominantly aqueous media, mild, beer, Cip - liquids. Very adhesive media can lead incorrect measurements.

Relevant welding sleeves on request.

The sealing of the sensor must have an intact electrical connection of the G1/2" thread and the container wall. Do not use any sealing strips

Installation Notes

Torque PEEK-Tip (HPTC-Tip) with sleeve (HPC-Sleeve): 20Nm



Pin Configuration

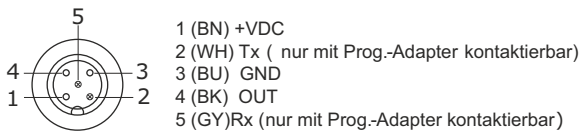

Order code

SGS-02 - 11 - S (A2) (HPC-Tip No. 2)

Version with longer peek tip

SGS-02 - 11 - S - P (A6) (HPC-Tip No. 6)

Accessories

PC-USB-Interface incl. Software to redout and parameterize

ST-PA-M12

Programming adapter (Y-Adapter M12) to connect the SGS with PC-USB-Interface

ST-M12-Y-AD

Weiteres Zubehör siehe Datenblatt Prozessanschlusstechnik

modular @ process

2023-06