

Differential pressure transmitter PASCAL Ci4 Delta P

for general application

Type series CI4300



Application area

- General process engineering
- Chemical and petrochemical industry
- General process technology

Features

- Differential pressure transmitter with metallic diaphragm
- Stainless steel case in sturdy design, degree of protection IP 65/67
- Accuracy 0.1 %
- High-resolution graphic display with Intuitive 4-button operation and backlight
- Comprehensive parameterising functions
- Comprehensive simulation and diagnostic functions
- Quick access to device data
- Development according to SIL2
- Nominal range 0.25 bar to 40 bar
- Turndown up to 100:1
- Measuring rate up to 100 Hz
- Output signal 4...20 mA with HART® protocol
- Configuration memory
- Digital communication via PDM, FDT/DTM, 375/475 Field Communicator
- Output functions: linear, invers, square root, table function with up to 64 support points
- Media temperature -20...100 °C
- Wetted parts stainless steel
- Approved according to NAMUR 95

Options

- Approvals / Certificates
 - Explosion protection (ATEX/IECEX/UKEX) for gases and dust
 - Classification per SIL2
- Calibration certificate per DIN EN 10204-3.1
- As per UKCA regulations
- Removable display and control unit
- Degree of protection IP 69K

Application

The digital differential pressure transmitter PASCAL Ci4 Delta P for general application is suitable for level measurement and filter monitoring in chemical/petrochemical and in general process engineering.

Technical data

Measuring ranges

Up to a turndown of 100:1 the measuring span can be freely selected.

Nominal range	Measuring span		Overload limit		Static excess pressure	Lower measuring range limit *
	min. span	max. span	plus-side	minus-side	both sides	
-0,25...0,25 bar	0,0025 bar	0,5 bar	10 bar	5 bar	75 bar	750 mbar abs
-1...1 bar	0,01 bar	2 bar	20 bar	10 bar	75 bar	30 mbar abs
-1...4 bar	0,04 bar	5 bar	50 bar	25 bar	75 bar	30 mbar abs
-1...16 bar	0,16 bar	17 bar	100 bar	75 bar	100 bar	30 mbar abs
-1...40 bar	0,4 bar	41 bar	100 bar	75 bar	100 bar	30 mbar abs

* Vacuum-proof designs are available upon request.

For information on definitions of terms regarding the Pressure Equipment Directive, see Technical Instruction TA_068.

Constructional design / case

Design:	Two-chamber case, continuously rotatable by $\pm 170^\circ$ Case surface blasted
Material case:	<ul style="list-style-type: none"> ■ Stainless steel mat.no. 1.4301/1.4305 (304/303) ■ Stainless steel mat.no. 1.4404 (316L)
Material front cover:	<ul style="list-style-type: none"> ■ Stainless steel mat.no. 1.4305 (303) ■ Stainless steel mat.no. 1.4404 (316L) ■ Polypropylene, black
Gaskets:	Silicone / NBR
Degree of protection per EN 60529:	IP 65 / IP 67 Option: IP 69K
Climatic category:	4K4H per EN 60721 3-4
Vibration resistance per EN 61298-3:	10...60 Hz: ± 0.35 mm 60...1000 Hz: 5 g
Material window:	<ul style="list-style-type: none"> ■ Non-splintering glass (requires front cover of stainless steel) ■ Polycarbonate
Elec. connection:	<ul style="list-style-type: none"> ■ Circular connector M12 ■ Cable gland M16x1.5, PA black ■ Cable gland M16x1.5, stainless steel ■ Cable gland M20x1.5, PA black ■ Cable gland M20x1.5, stainless steel ■ 1/2" NPT, PA black <p>Further connections upon request</p>
Terminal blocks:	<ul style="list-style-type: none"> ■ Spring clamp terminals up to 1.5 mm² ■ Pole terminals up to 2.5 mm² ■ Screw terminals up to 2.5 mm²
Weight:	approx. 1.4 kg (without process connection)
Type plate:	Laser marking

Process connection

Design:	Process flange with connection dimension per DIN EN 61518
	<ul style="list-style-type: none"> ■ Process connection 1/4 – 18 NPT Mounting thread 7/16 – 20 UNF ■ Cutting ring fitting stainless steel per DIN 2353 <ul style="list-style-type: none"> – for pipe \varnothing 6 mm, mounted – for pipe \varnothing 8 mm, mounted – for pipe \varnothing 10 mm, mounted – for pipe \varnothing 12 mm, mounted ■ Process connection 1/2 – 14 NPT via oval flange (see accessories)
	Process flange incl. 1/4" NPT sealing plug, alternative with vent valve. The process flange is rotatable. Further process connections upon request.

Material wetted parts

Process flange:	Stainless steel, mat.-no. 1.4408
Diaphragm:	Stainless steel, mat.-no. 1.4404/1.4435 (316L)
Gasket:	FKM
Ventilation valve:	Stainless steel, mat.-no. 1.4404 (316L)
Sealing plug:	Stainless steel 316L

Measuring system

Sensor:	Piezoresistive measuring element
System filling:	Synthetic oil FD1, free of silicone, FDA compliant

Accuracy

Reference cond. per EN 61298-1:	$T_U = \text{const. (15...25) } ^\circ\text{C}$ $\varphi = \text{const. (45...75) \% r.F.}$ $p_U = \text{const. (860...1060) mbar}$ $U_B = 24 \text{ V DC } (\pm 3 \text{ V DC})$ $R_B = 50 \text{ } \Omega$, HART: 250 Ω Ground connected $MBA = 0 \text{ bar}$
Calibration position:	Process connection bottom: vertical
Deviation of characteristic:	Refer to the adjusted measuring span (Limit point method per DIN 16086) Nominal range 1-40 bar Turndown 5:1 0.1 % Turndown > 5:1 0.02 % x TD Nominal range 0.25 bar Turndown 5:1 0.15 % Turndown > 5:1 0.03 % x TD
Long-term drift:	Refer to nominal range $\leq 0.1 \text{ \% / year}$
Operational availability	< 12 s
Response time t_{90} at current output	for 20 Hz measuring rate: typically 120 ms for 100 Hz measuring rate: typically 50 ms
Temperature influence, case:	Refer to nominal range Ambient temperature -20...80 °C: Nominal range 1-40 bar 0.1 %/10K, max. 0.3 % Nominal range 0.25 bar 0.15 %/10K, max. 0.4 % Ambient temperature -40...-20 °C: Typical 0.2 %/10K
Influence static pressure:	Refer to nominal range 0.25 bar 0.12 % x stat. pressure [bar] x TD 1 bar 0.03 % x stat. pressure [bar] x TD 4 bar 0.02 % x stat. pressure [bar] x TD 16 bar 0.002 % x stat. pressure [bar] x TD 40 bar 0.001 % x stat. pressure [bar] x TD

Indication

Display:	- High-resolution graphic display with backlight - 4-button operation - Freely configurable display modes - continuously rotatable
----------	---

- Optional: Remote display and control unit (max. 10 m)

Configuration memory: All parameterisation data can be copied from the device into the configuration memory in the display module. The data is permanently stored there, even in the event of power failure.

The parameters can be transferred simply and quickly to other devices.

Output

Signal:	2-wire technology	4...20 mA
	Lower limit	3.8...4 mA
	Upper limit	20...21 mA
	Lower alarm current	< 3.6 mA
	Upper alarm current	> 21 mA
	Current limitation	22 mA
Digital communication:	HART ® protocol, version 7	

Device driver:

- EDD für SIMATIC PDM
- DTM for PACTware or compatible systems (FDT compliance)
- EDD for 375 / 475 Field Communicator

Function:	<ul style="list-style-type: none"> ■ linear ■ inverse response ■ by square root ■ table function with up to 64 support points
-----------	---

Turndown: Max. 100:1

Damping: 0...999.9 s selectable in steps of 0.1 s

Measuring rate: 20 Hz, switchable to 100 Hz

Resolution: 0.5 μA

Current sensing func. 3.55...21.5 mA selectable in steps of 0.001 mA

Load R: $R \leq (U-12\text{V DC})/0.022 \text{ A } [\Omega]$

$U = \text{supply voltage}$

for HART ® communication $R \geq 230 \text{ } \Omega$

Supply voltage

Functional range:	12...30 V DC, protected against polarity reversal
Ripple:	< 5 %

Temperature ranges

Ambient:	-40...80 °C (Display visibility is limited at temperatures below -30 °C)
Media:	-20...100 °C
Storage:	-40...80 °C

Tests and certificates

Ex approvals

ATEX:	TÜV 13 ATEX 120264 X ⊕ II 1/2G Ex ia IIC TX Ga/Gb ⊕ II 1/2D Ex ia IIIC Txx °C Da/Db ⊕ II 2G Ex ia IIC TX Gb ⊕ II 2D Ex ia IIIC Txx °C Db
IECEX:	IECEX TUN 13.0018X Ex ia IIC TX Ga/Gb Ex ia IIIC Txx °C Da/Db Ex ia IIC TX Gb Ex ia IIIC Txx °C Db
UKEX:	CML 21UKEX21179X ⊕ II 1/2G Ex ia IIC TX Ga/Gb ⊕ II 1/2D Ex ia IIIC Txx °C Da/Db ⊕ II 2G Ex ia IIC TX Gb ⊕ II 2D Ex ia IIIC Txx °C Db

For more detailed information see Ex Safety Instruction XA_011.

EMC :	per EN 61326-1, NAMUR NE21
SIL 2:	Functional safety per EN 61508, classification per SIL2 For detailed information see SIL instruction SA_001
NAMUR:	Approved according to NE95, Test report TP14033 available upon request

Parameterisation, simulation and adjustment

Parameterisation

Parameter	Values	Default setting
Device		
device ID	16 digits, freely selectable	LABOM PASCAL Ci4
lower range value	at any value within nominal range	0 bar
upper range value	at any value within nominal range	end of nominal range
measuring rate	20 Hz, 100 Hz	20 Hz
damping	0.0...999.9 s	0.0 s
Display and control unit		
pressure unit	mbar, bar, Pa, hPa, kPa, MPa, g/cm ² , kg/cm ² , psi, atm, torr, mmH ₂ O, mH ₂ O, inH ₂ O, ftH ₂ O, mmHg, inHg	bar
temperature unit	°C, °F, °R, K	°C
lighting	on, off	on
language	English, German	German
	English, Chinese	as ordered
	English, Spanish, French	as ordered
	English, Polish, German	as ordered
	English, Turkish, German	as ordered
decimal point	auto, x.xxxx, xx.xxx, xxx.xx, xxxx.x, xxxxx	auto
display mode	five values, four values, three values, two values, big display	four values
main value	pressure, current in %, current in mA	pressure
secondary values	pressure, current in %, current in mA, sensor temperature, device ID, HART-TAG, HART-Descriptor, <empty>	current in %, current in mA, device ID
Current output		
output function	linear, inverse response, by square root, table function	linear
lower current limit	3.8...4.0 mA	3.8 mA
upper current limit	20...21 mA	20.5 mA
alarm current	low (<3.6 mA), high (> 21.0 mA)	low (<3.6 mA)
position correction (mounting position)	on, off	off
Maintenance counter		
maintenance interval	0...9999 days	0 days
status	on, off	off
HART data		
HART address	0...63	0
number of response preambels	5...20	5
current mode	proportional, constant	proportional

Diagnostic functions

Self- diagnosis	Description	Value range
RAM-Test	Permanent check of the read/write memory	/
ROM-Test	Permanent check of the checksum via the program memory	/
Bridge circuit test	Permanent check of the bridge circuit	/
CRC parameterisation test	Permanent check of the checksum via the parameter memory	/
Electronics temperature monitoring	Permanent check of the electronics temperature	/
Process diagnostics		
Maintenance timer	Check of the maintenance cycles	/
Operating hours counter	Capture of operating hours	/
Min/Max values	Check of minimum and maximum process pressure and sensor temperature	/
Measuring circuit diagnostics		
loop-test	Setting of a fixed current value at the output	3,55...21,5 mA
pressure simulation	Setting a fixed pressure value, it also considers damping and tabular function unlike the current simulation	Nominal range

Adjustment

Type	Description
zero point correction	adjusts reading to 0 bar at same pressure on both connections
position correction	adjusts reading of mounted instrument to 0 bar at same pressure on both connections
lower adjustment	adjusts reading to applied pressure (affects zero point + span)
upper adjustment	adjusts reading to applied pressure (affects span only)
current adjustment	adjusts current output to achieve 4 resp. 20 mA at the end of the measurement chain

Connection diagram

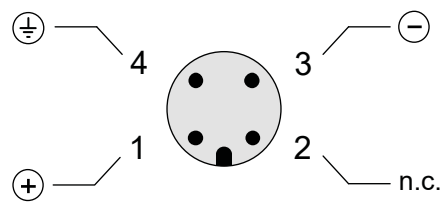
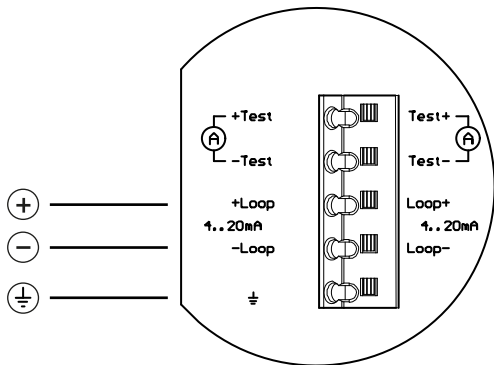

Cable gland

Circular connector M12 x 1

Dimensions

Case and process connections

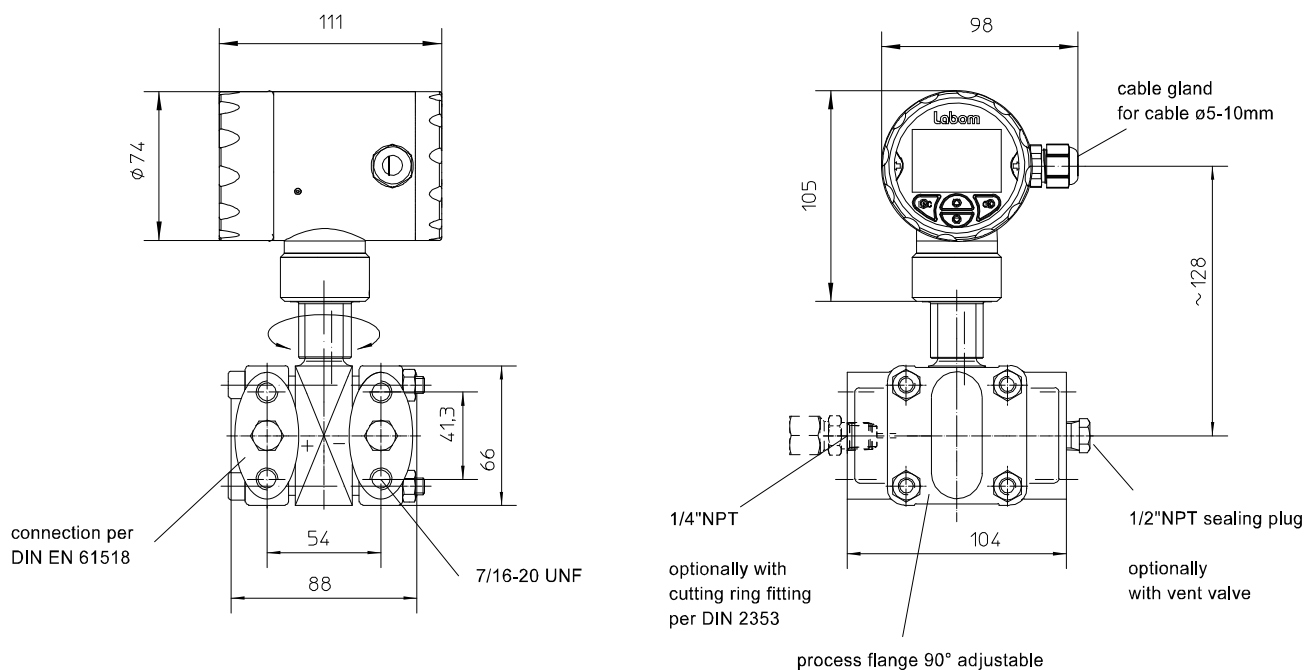

All dimensions are in mm

Follow-up case and process connections

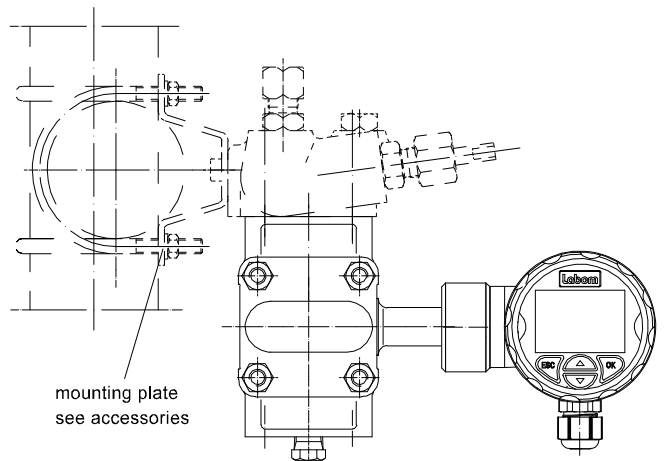
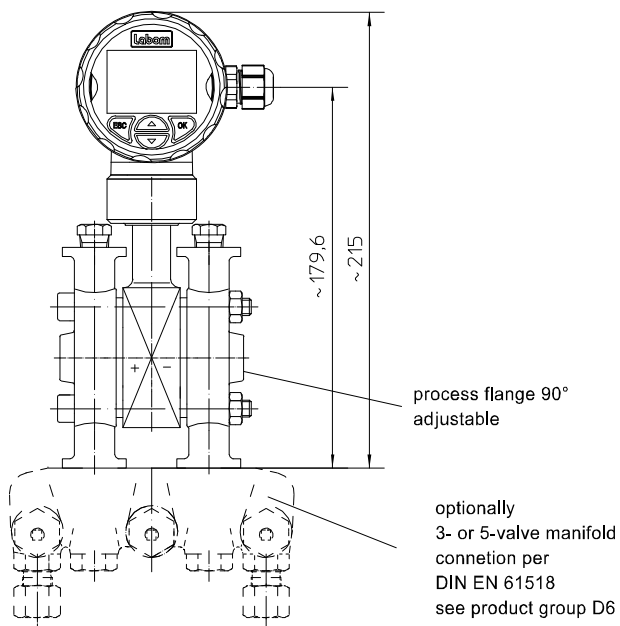
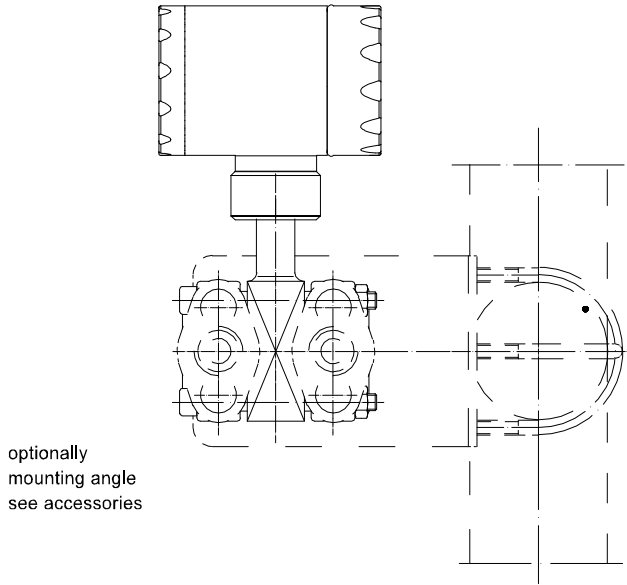
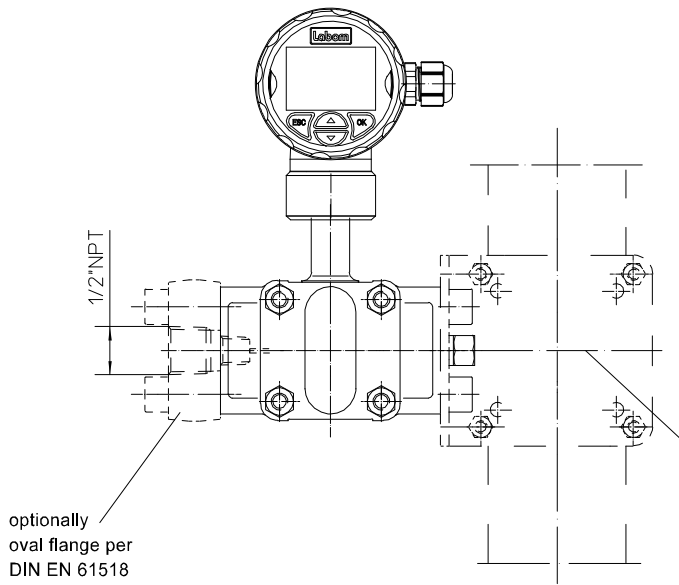

All dimensions are in mm

Electrical connections

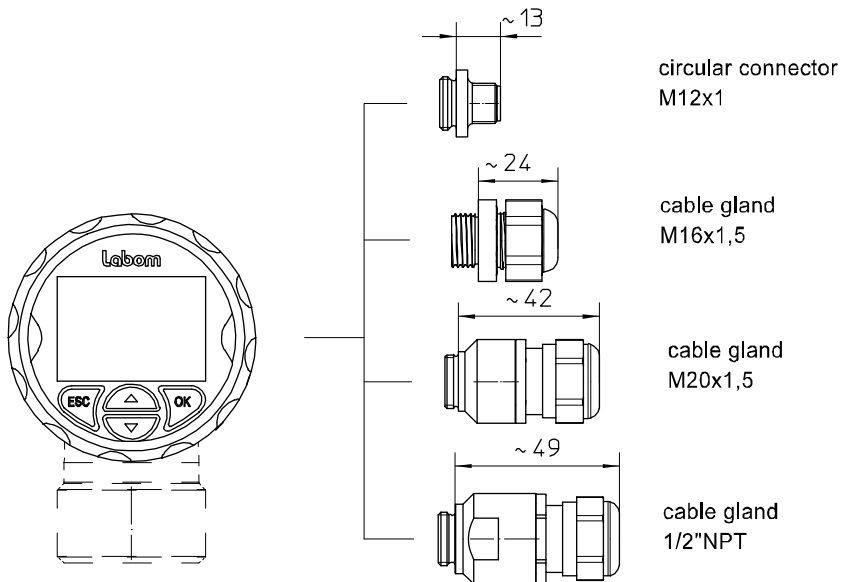

All dimensions are in mm

Remote display and control unit (Type series MC1140)

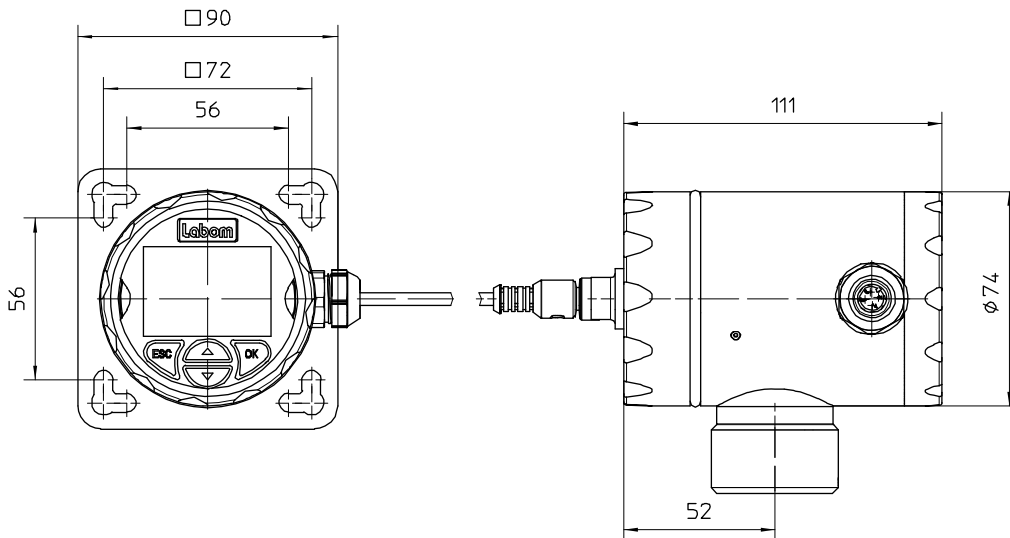

All dimensions are in mm

Mounting angle for wall and pipe-mounting (Type series MM1500)

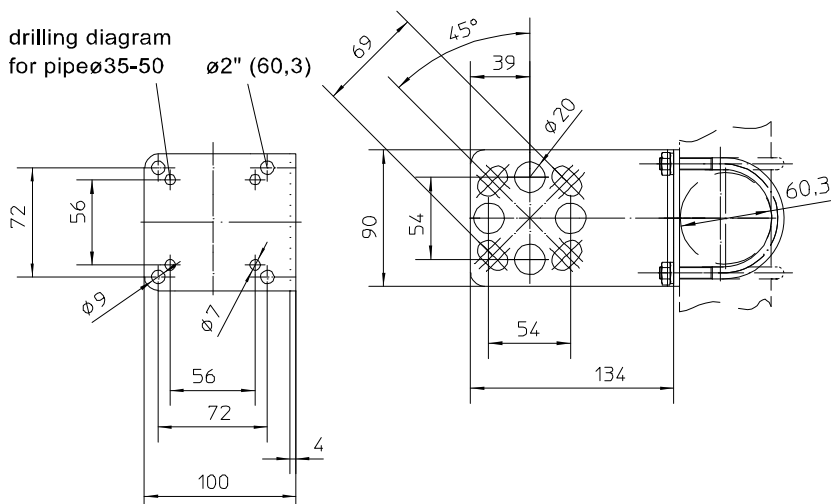

All dimensions are in mm

Order details

Differential pressure transmitter PASCAL Ci4 Delta P for general application				
CI4300	Differential pressure transmitter	PASCAL Ci4 Delta P for general application		
A1078	nominal range	-0.25...0.25 bar		
A1053		-1...1 bar		
A1056		-1...4 bar		
A1059		-1...16 bar		
A1061		-1...40 bar		
F1	parameterisation	factory settings (standard)		
F2		as per customer's specification (pls. specify)		
H21	output signal	4...20 mA, with HART-protocol		
Y1.	material case	stainless steel mat.-no. 1.4301/1.4305 (304/303)		
Y2.		stainless steel mat.-no. 1.4404 (316L)		
1	material front cover	polypropylene (black), window polycarbonate		
2		stainless steel (see case), window non-splintering glass		
3		stainless steel (see case), closed, without window		
			default language	available language
M21.1	display	high-resolution graphic display with backlight, intuitive 4-button operation, quick access to device data	German (standard)	English, German
M22.1			English	
M22.2			Chinese	English, Chinese
M23.1			English	
M23.2			Spanish	English, Spanish, French
M23.3			French	
M25.1			English	English, Polish, German
M25.2			Polish	
M25.3			German	
M26.1			English	English, Turkish, German
M26.2			Turkish	
M26.3			German	
M1		without display		
T20.	electrical connection	cable gland	M16 x 1.5 polyamide, for cable Ø 4.5-10	
T22.			M16 x 1.5 stainless steel, for cable Ø 5-9.5 mm	
T15.			M20 x 1.5 polyamide, for cable Ø 7-13 mm	
T17.			M20 x 1.5 stainless steel, for cable Ø 8-13 mm	
T27.			1/2" NPT polyamide, for cable Ø 6-12 mm	
0		cable clamps	spring clamp terminals up to 1.5 mm ²	
5			pole terminals 2.5 mm ²	
6	screw terminals 2.5 mm ²			
T30		circular connector M12 x 1 (4-polig)		
K41 . 1	process connection	process flange with connection dimension per DIN EN 61518, process flange horizontal - process connection 1/4 – 18 NPT - mounting thread 7/16 – 20 UNF		
K43 . 1		process flange with connection dimension per DIN EN 61518, process flange vertical (turned by 90°) - process connection 1/4 – 18 NPT - mounting thread 7/16 – 20 UNF		
3		with sealing plug of stainless steel 316L		
4		with ventilation valve of stainless steel mat.-no. 1.4404 (316L)		
	threaded pipe connection	without cutting ring fitting		
.1		incl. 2 x cutting ring fittings	stainless steel per DIN 2353 for pipe ø 6 mm, mounted	
.2			stainless steel per DIN 2353 for pipe ø 8 mm, mounted	
.3			stainless steel per DIN 2353 for pipe ø 10 mm, mounted	
.4			stainless steel per DIN 2353 for pipe ø 12 mm, mounted	
G1	diaphragm material	stainless steel mat.-no. 1.4404 / 1.4435 (316L)		
P2	media temperature	-20...100 °C		

Additional features (to be indicated if required)			
S62	Ex marking ¹	ATEX	II 1/2G, II 2G Ex ia IIC TX Ga/Gb, Gb
			II 1/2D, II 2D Ex ia IIIC Txx °C Da/Db, Db
S77		IECEX	Ex ia IIC TX Ga/Gb, Gb
			Ex ia IIIC Txx °C Da/Db, Db
S87		UKEX	II 1/2G, II 2G Ex ia IIC TX Ga/Gb, Gb
			II 1/2D, II 2D Ex ia IIIC Txx °C Da/Db, Db
T4	degree of protection	IP 69K ¹	
W1201	calibration certificate	per EN 10204-3.1, 5 measuring points	
W2602	functional safety per EN 61508, classification per SIL2		
W2660	as per UKCA regulations		

Accessories			
MM1500-A11	mounting angle	for wall and pipe-mounting Ø 35-50 mm of stainless steel, incl. screws 7/16-20 UNF	
MM1500-A12		for wall and pipe-mounting Ø 2" of stainless steel, incl. screws 7/16-20 UNF	
MC1060-A132	oval flange	oval flange 1/2-14 NPT per DIN EN 61518, modal A of stainless steel mat.-no. 1.4404 (316L), incl. 2 screws 7/16-20 UNF, material stainless steel, incl. gasket PTFE	
MC1060-A133		oval flange 1/2-14 NPT per DIN EN 61518, modal A of stainless steel mat.-no. 1.4404 (316L), incl. 2 screws 7/16-20 UNF, material stainless steel, incl. gasket FKM	
MC1140	PASCAL Ci4 remote display and control unit including device holder		
	material stainless steel, incl. front ring with seal and blind cap with circular connector M12x1		
A1.	connection cable	length: 10 m, material: PUR, with circular connector M12 x1 (further lengths upon request)	
1	internal cable clamps	spring clamp terminals up to 1.5 mm ²	
2		pole terminals 2.5 mm ²	
3		screw terminals 2.5 mm ²	
T1	degree of protection	IP 65 / IP 67 (standard)	

Order code (example): CI4300 – A1056 – F1 – H21 – Y12 – T200 – K4111 – G1 - ...

¹ Requires front cover of stainless steel.