

# Differential pressure transmitter UNIVERSAL

## for filter monitoring

### Type series CP131.



#### Application area

- General process technology
- Power engineering
- Machinery construction

#### Technical Data

##### Housing designs

material: st. steel mat.-no. 1.4301 (304)  
 degree of protection: IP 65  
 silicon cover plate for trimming potentiometers.  
 Right angle plug as per DIN EN 175301-803-A  
 (DIN 43650, form A) with cable gland  
 M16x1.5 mm, cable diameter 4...10 mm

##### Process connection

2 x NPT 1/4 - 18, standard distance 54 mm.  
 Option: compression fitting (Ermeto).  
 Further models upon request

##### Measuring system

piezoresistive measuring bridge, protected  
 by integrated stainless-steel diaphragm

##### Filling material

silicone-free synthetic oil

##### Material

diaphragm: st. steel mat.-no. 1.4404 (316L)  
 cell: st. steel mat.-no. 1.4404 (316L)

##### Weights

standard housing: approx. 1030 g

##### Storage temperature range

-25...+80 °C

##### Limiting temperature range

-25...+70 °C

##### Rated temperature range

-10...+70 °C

##### Temperature influence

on zero point:  $\leq 0.05$  % of meas. span /K  
 on meas. span:  $\leq 0.05$  % of meas. span /K

##### Auxiliary power supply

standard version:  
 · nominal voltage 24 V DC  
 · function range  
 2-wire circuitry 14...30 V DC  
 3-wire circuitry 16...30 V DC  
 · max.permiss.operating voltage 30 V DC

##### Ex design:

· permiss. voltage range of 2-wire circuitry  
 15...30 V DC

##### Ex design:

· permiss. voltage range of 3-wire circuitry  
 16...30 V DC

##### Standard measuring ranges

see order details

##### Overload limits one sided and static excess pressure both sides

see order details

##### Overload influence

$\leq 0.1$  % f.s.

##### Output signal

4...20 mA, 2-wire circuitry, standard.  
 Other signals see order details.

##### Current limitation in output signal

max. output current approx. 30 mA

##### Supply voltage influence

$\leq 0.2$  % f.s. / 10 V

#### Features

- Small, solid design
- Wetted parts of stainless steel
- Measuring ranges 0...250 mbar up to 0...25 bar
- Zero point and measuring span can be adjusted externally by means of a potentiometer
- Output signal: 4...20 mA 2-wire circuitry  
 0...20 mA 3-wire circuitry  
 0(2)...10 V 3-wire circuitry

#### Options

- Explosion protection
- As per UKCA regulations

#### Application

The analog pressure transmitter UNIVERSAL is suited for measuring the differential pressure of gases. The area of application lies in general filter monitoring.

##### Adjusting range

zero point and measuring span  
 approx.  $\pm 10$  %

##### Response time

$\leq 20$  ms

##### Linearity error incl. hysteresis

$\leq 0.5$  % f.s. (terminal based)

##### Electrical data

Sum of maximum values in the intrinsically safe circuits  
 $U_i = 30$  V  
 $I_i = 100$  mA  
 $P_i = 0,7$  W

The table shows the values for different pressure transmitter signals:

signal mode	Ci [nF]	Li [ $\mu$ H]
2-wire 4...20 mA	33	20
3-wire 0(2)...10 V	43	30
3-wire (0)4...20 mA	43	30

##### Caution:

Make sure that there is equipotential bonding along the entire wiring run both inside and outside the explosion hazardous area. Switch off device if it is installed in zone 0 and in temperature class T5 and T6 and it fails!

**Ex-approval**

The limit values detailed in the EC-Type Examination Certificate are to be observed!

EC-Type Examination Certificate TÜV 02 ATEX 1971 X and IECEx TUN 04.0008X

type of ex-protection:

- ⊕ II 1/2G Ex ia IIC T4/T5/T6 Ga/Gb
- ⊕ II 2G Ex ia IIC T4/T5/T6 Gb

IECEX TUN 04.0008X

type of ex-protection:

- Ex ia IIC T4/T5/T6 Ga/Gb
- Ex ia IIC T4/T5/T6 Gb

Ex ia I Ma

Since the intrinsically safe circuits are connected with the earth potential for safety reasons, potential equalization has to exist in the complete course of the erection of the intrinsically safe circuits.

**Ambient temperatures**

- ⊕ II 1/2G Ex ia IIC T4/T5/T6 Ga/Gb
- Ex ia IIC T4/T5/T6 Ga/Gb

Ta [°C]	TM [°C]	temperature class
70	40	T6
70	60	T5
70	60	T4

**Ambient temperatures**

- ⊕ II 2G Ex ia IIC T4/T5/T6 Gb
- Ex ia IIC T4/T5/T6 Gb

Ta [°C]	TM [°C]	temperature class
70	55	T6
70	70	T5
70	70	T4

**Ambient temperatures Ex ia I Ma:**

Ta = Tm 70°C max

**Burden**

- current output  
2-wire circuitry  
standard version  $R_a = \frac{U_b - 14 V}{20 \text{ mA}}$  (KOhm)
- with explosion protection  $R_a = \frac{U_b - 15 V}{20 \text{ mA}}$  (KOhm)
- voltage output  
a current of 20 mA can be obtained in the case of devices with power output.

**Burden influence**

for 500 Ohm burden of change: ≤ 0.1 % f.s.

**EMC-Test**

- noise immunity as per EN 50082, section 2, March 95 issue for industry
- emitted interference as per EN 50081, section 1, 1993 issue for residential and industrial areas

**Information on other models see order details or upon request.**



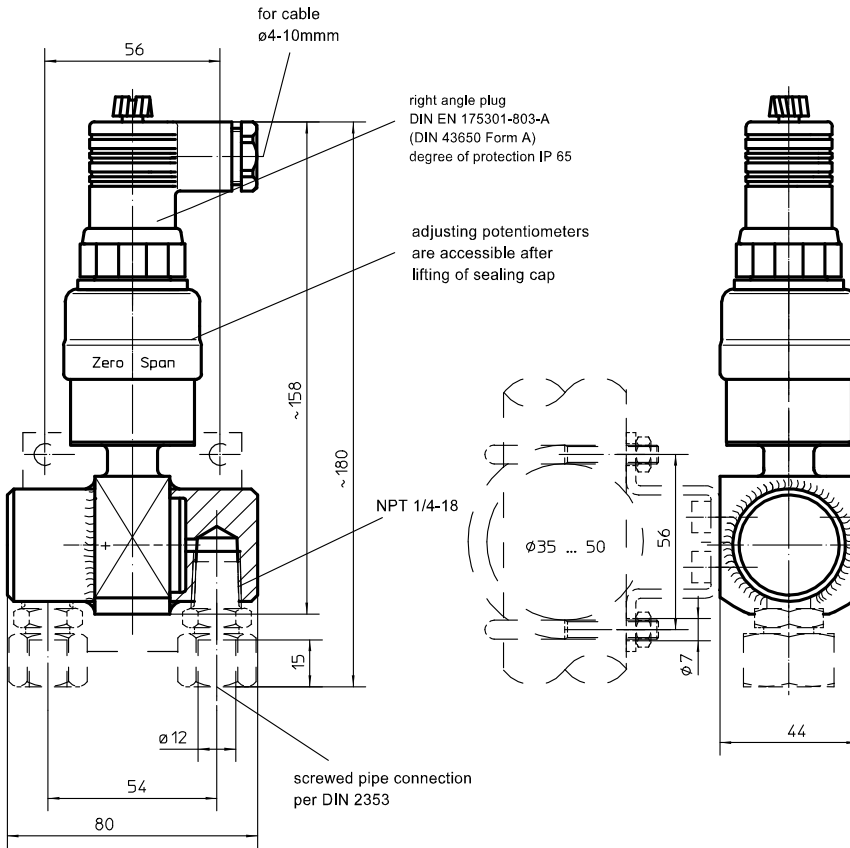

**Dimensions**

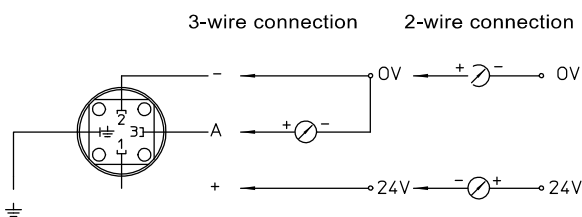

**Connection diagram**



## Order details

Differential pressure transmitter UNIVERSAL for filter monitoring							
design	· standard			CP1310			
	· explosion protection, type of ex-protection s. below			CP1311			
measuring range	differential nominal pressure	overload limits one-sided (+side or -side)	static excess pressure (both sides)				
	0...250 mbar	2 bar	75 bar			A1010	
	0...400 mbar	6 bar	75 bar			A1051	
	0...0.6 bar	6 bar	75 bar			A1052	
	0...1 bar	6 bar	75 bar			A1053	
	0...1.6 bar	10 bar	75 bar			A1054	
	0...2.5 bar	10 bar	75 bar			A1055	
	0...4 bar	16 bar	75 bar			A1056	
	0...6 bar	30 bar	75 bar			A1057	
	0...10 bar	30 bar	75 bar			A1058	
	0...16 bar	50 bar	75 bar			A1059	
	0...25 bar	50 bar	75 bar			A1060	
output signal	· 4...20 mA, 2-wire					H1	
	· 0...20 mA, 3-wire					H2	
	· 0...10 V, 3-wire					H4	
	· 0...5 V, 3-wire					H6	
<b>additional features (to be indicated in case of need, only)</b>							
process connection	with screwed pipe per DIN 2353 (Ermeto compression fitting)		· 6 mm			K11	
			· 8 mm			K12	
			· 10 mm			K13	
			· 12 mm			K14	
type of ex-protection (for ex-protection only)	·  II 2G Ex ia IIC T4 Gb					S69	
	·  II 2G Ex ia IIC T5/T6 Gb, standard					S68	
	·  II 1/2G Ex ia IIC T4 Ga/Gb					S62	
	·  II 1/2G Ex ia IIC T5/T6 Ga/Gb					S66	
	IECEX	· Ex ia IIC T4/T5/T6 Ga/Gb					S76
· Ex ia IIC T4/T5/T6 Gb							
· Ex ia I Ma							
assembly set	· mounting clip					V2	
As per UKCA regulations						W2660	
<b>Order code (example)</b>				CP1310	A1053	H1	

For information on definitions of terms regarding the Pressure Equipment Directive, see Technical Instruction TA\_068.