



Badger Meter Europa GmbH

B-MAG I M5000



INSTALLATION AND OPERATION MANUAL

October 2016

MID_M5000_BA_02_1610

1. Basic safety recommendations	1
2. System description	3
3. Installation	4
3.1 General information	4
3.1.1 Temperature ranges	4
3.1.2 Protection class	4
3.1.3 Transport	5
3.2 Installation.....	6
3.2.1 Meter orientation.....	6
3.2.2 Inlet and outlet pipe	6
3.2.3 Meter location	7
3.2.4 Pipe reducer requirements	8
3.2.5 Separate version.....	9
3.2.6 Grounding and potential equalization	9
3.2.7 Plastic or lined pipelines	10
3.2.8 Pipelines with cathodic protection.....	10
3.2.9 Electrically disturbed environment.....	11
4. Electrical connections	12
4.1 Power.....	13
4.1.1 Battery	13
4.1.2 Battery backup.....	14
4.2 Separate version.....	15
4.2.1 Connection on the amplifier	15
4.2.2 Connection on the detector.....	15
4.2.3 Signal cable specification	17
4.3 Configuring input/output (I/O).....	18
5. Parametering	19
6. Main menu	21
7. Troubleshooting	34
7.1 Replace meter's electronics	36
8. Technical data	37
8.1 Detector type VI	37
8.2 Amplifier type B-MAG I M5000	39
8.3 Error limits.....	40
8.4 OIML approved meter	41
8.5 MID approved meter (MI-001).....	42
8.6 Size selection.....	43



9. Programm structure	44
10. Spare parts.....	47
11. Return of goods for repair.....	48



1. Basic safety recommendations

Before installing or using this product, please read this instruction manual thoroughly. Only qualified personnel should install and/or repair this product. If a fault appears, contact your distributor.

The electromagnetic flow meter is only suitable for the measurement of conductive fluids. The manufacturer is not liable for damages that result from improper use or from use that is not in accordance with the requirements.

The meters are constructed according to state-of-the-art technology and tested operationally reliable. They have left the factory in a faultless condition concerning safety regulations.

The mounting, electric installation, putting into operation and maintenance of the meter is to be carried out by suitable technicians. Furthermore the operating personnel has to be trained by the operating authority and the instructions of this manual have to be followed.

Basically you have to respect the regulations for the opening and repairing of electrical equipment applicable in your country.

Installation

Do not place any unit on an unstable surface that may allow it to fall.
Never place the units above a radiator or heating unit.
Route all cabling away from potential hazards.
Isolate from the mains before removing any covers.

Power connection

Use only the type of power source suitable for electronic equipment. If in doubt, contact your distributor. Ensure that any power cables are of a sufficiently high current rating. All units must be earthed to eliminate risk of electric shock. Failure to properly earth a unit may cause damage to that unit or data stored within it.

Protection class

The device has protection class IP 67/68.

Setup & operation

Adjust only those controls that are covered by the operating instructions. Improper adjustment of other controls may result in damage, incorrect operation or loss of data.

Cleaning

Switch off all units and isolate from mains before cleaning.
Clean using a damp cloth. Do not use liquid or aerosol cleaners.



Repair of faults

Disconnect all units from power supply and have it repaired by a qualified service person if any of the following occurs:

- If any power cord or plug is damaged or frayed
- If a unit does not operate normally when operating instructions are followed
- If a unit exposed to rain/water or if any liquid has been spilled into it
- If a unit has been dropped or damaged
- If a unit shows a change in performance, indicating a need for service.



RoHs

Our products are RoHs compliant.

Battery disposal

The batteries contained in our products need to be disposed of as per your local legislation acc. to EU directive 2006/66/EG.



2. System description

The electromagnetic flow meters are intended for the metering of all fluids with electric conductivity of at least $5 \mu\text{S}/\text{cm}$ ($20 \mu\text{S}/\text{cm}$ for demineralized water). These series of meters is characterized by a high degree of accuracy. Measuring results depend on density, temperature and pressure.

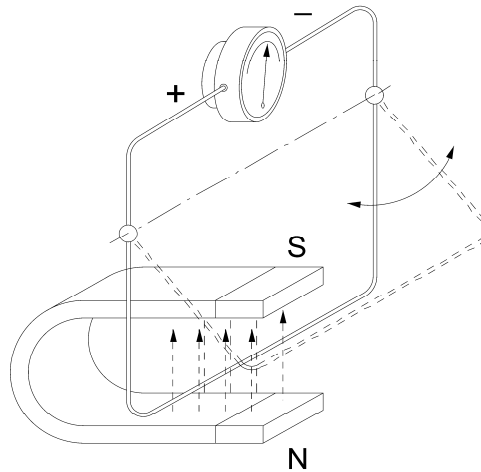

Measuring principle

In accordance with Faraday's induction principle, electric voltage is induced in a conductor moving through a magnetic field. In case of the electromagnetic flow measurement, the moving conductor is replaced by the flowing fluid. Two opposite measuring electrodes conduct the induced voltage which is proportional to flow velocity to the amplifier. Flow volume is calculated based on pipe diameter.

3. Installation

Warning: • *Installation instructions given below are to be observed in order to guarantee a perfect functioning and a safe operation of the meter.*

3.1 General information

3.1.1 Temperature ranges

- Caution:** • *In order to prevent the meter from any damaging, you are requested to strictly observe amplifier's and detector's maximum temperature ranges.*
- *In regions with extremely high ambient temperatures, it is recommended to protect the detector.*
 - *In cases where fluid temperature exceeds 100°C, foresee separate amplifier and detector (separate version).*

Amplifier	Ambient temp.		-20 to + 60 °C
Detector	Fluid temp.	PTFE / PFA	-40 to +150 °C
		Hard rubber	0 to +80 °C
		Soft rubber	0 to +80 °C

3.1.2 Protection class

In order to fulfill requirements in respect of the protection class, please follow the following guidelines:

- Caution:** • *Body seals need to be undamaged and in proper condition.*
- *All of the body screws need to be firmly screwed.*
 - *Outer diameters of the used wiring cables must correspond to cable inlets (for M20 Ø 7....12 mm). In cases where cable inlet is not used, put on a dummy plug.*
 - *Tighten cable inlets.*
 - *If possible, lead cable away downwards to avoid humidity goint into cable inlet.*

We normally deliver the meter in accordance with protection class IP 67. If you however require a higher protection class, the amplifier is to be installed separately from the detector. If requested, we can also deliver the detector in IP 68.



3.1.3 Transport

- Caution:** • *Use lifting lugs when lifting meter flow tubes that are 150 in diameter or larger.*

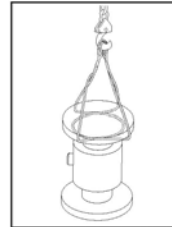
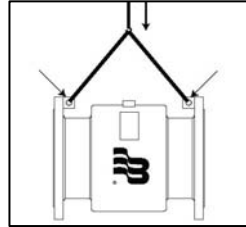

- *Do not lift meter on measuring amplifier or on detector's neck.*
- *Do not lift meter with a fork lift on the jacket sheet. This could damage the body.*

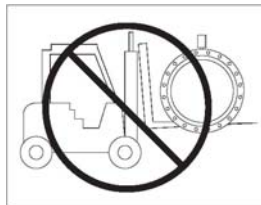

- *Never place rigging chains, forklift forks, etc. inside or through the meter's flow pipe for hoisting the meter. This could damage the isolating liner.*



3.2 Installation

In order to provide a perfect functioning and to prevent the meter from eventual damages, please follow the following installation instructions.

- Caution:**
- *Carefully observe the forward flow label on the meter body and install the meter accordingly.*
 - *As for detectors with PTFE liner, remove protective cap on the flange not until shortly before installation.*

3.2.1 Meter orientation

Meters can operate accurately in any pipeline orientation. Meters can be installed in horizontal as well as in vertical pipelines.

Meters perform best when placed vertically with liquid flowing upward as it prevents solids build-up.

When installing the meter on a horizontal pipe, mount the meter to the pipe with the flow measuring electrode axis in a horizontal plane as it prevents gas bubbles to result in a temporary isolation of the flow measuring electrodes.

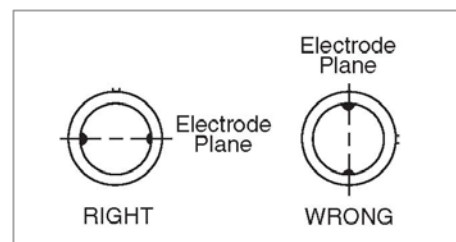

Carefully observe the forward flow label on the meter body and install the meter accordingly.

3.2.2 Inlet and outlet pipe

Always install the detectors in front of fittings producing turbulences. If this is not possible, foresee distances of $> 3 \times DN$. Distance ought to be $> 2 \times DN$.

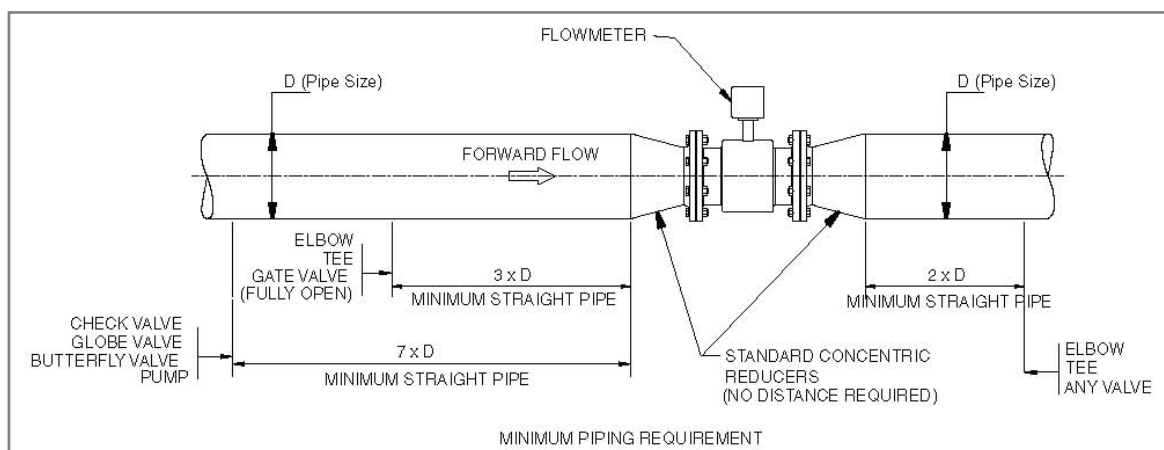

3.2.3 Meter location

- Caution:**
- Do not install the detector on the suction sides of pumps. This could damage the liner (in particular PTFE liners).
 - Verify that the pipeline is always filled on the measuring point, if not - a correct or accurate measurement is not possible.
 - Do not install the detector on the highest point of a pipeline system. Gas accumulation may follow.
 - Do not install the detector in downcomer pipes with free outlet.
 - Do not install the detector on pipes with vibrations. If pipes are strongly vibrating, make sure that detector and amplifier are separated (separate version).

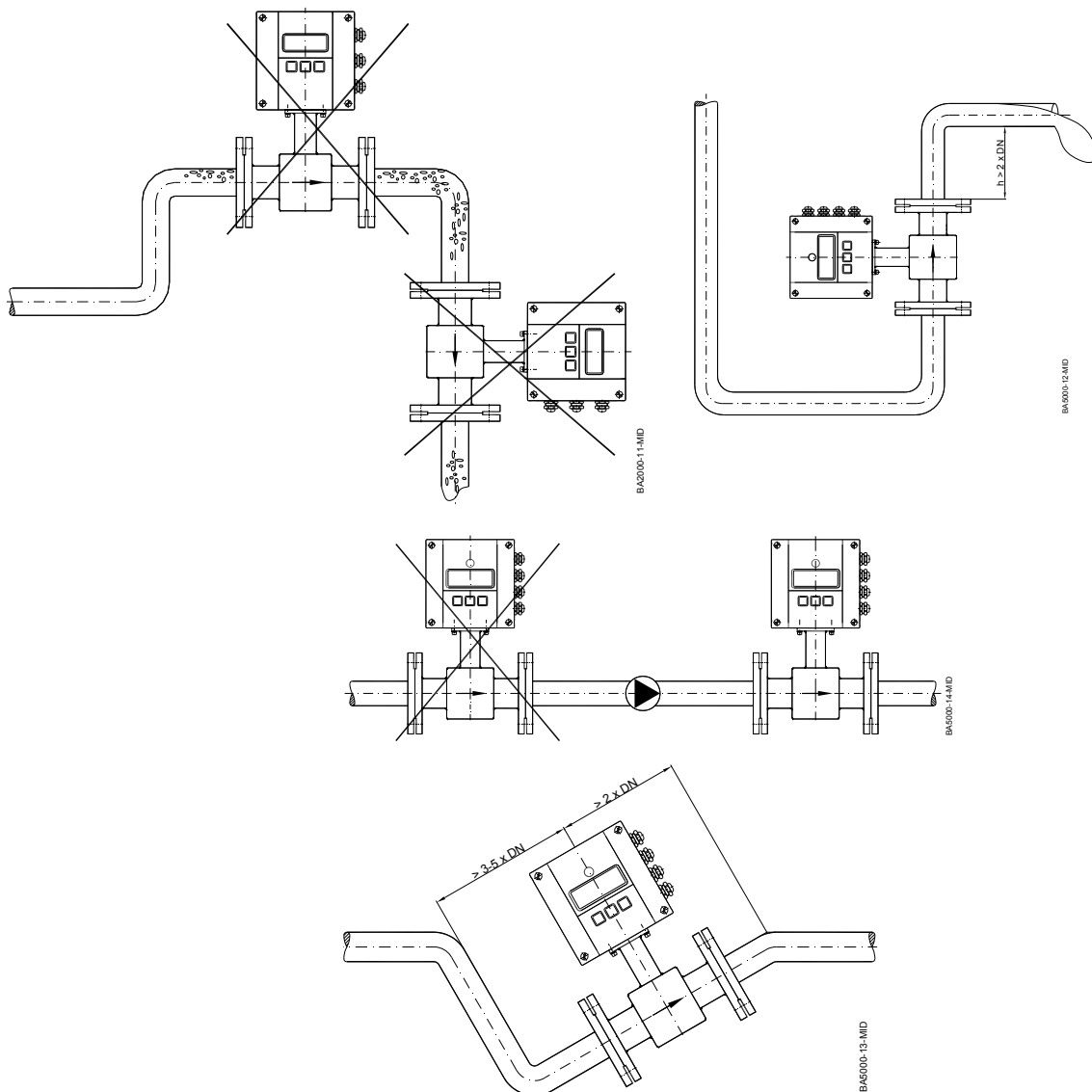

3.2.4 Pipe reducer requirements

With pipe reducers as per DIN 28545 detectors can be mounted in larger pipelines.

You can determine the occurring pressure drop by using the shown nomogram (only applicable to liquids with similar viscosity like water).

Note: • In cases where flow velocities are very low, you can increment them by reducing the size on the measuring point and hence obtain a better measuring accuracy.

D = pipeline
d = detector

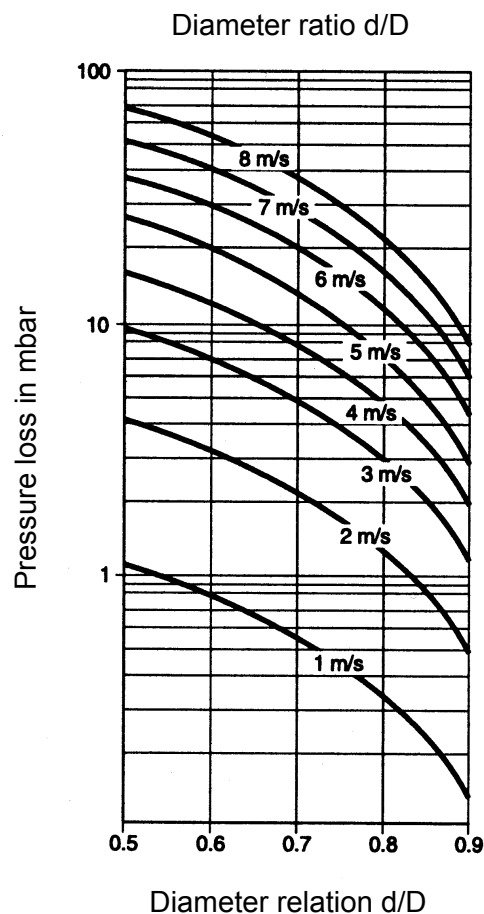
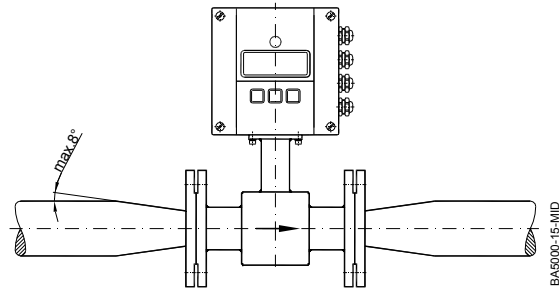

Define pressure loss:

1. Calculate diameter ratio d/D.
2. Read pressure loss depending on d/D ratio and flow velocity.



3.2.5 Separate version

Provide a separate version in the following cases:

- Note:*
- *Detector protection class IP 68*
 - *Fluid temperature > 100 °C*
 - *Strong vibrations*

- Caution:*
- *Do not install the signal cable close to power cables, electric machines, etc.*
 - *Fix signal cables. Due to capacity changes, cable movements may result in incorrect measurements.*

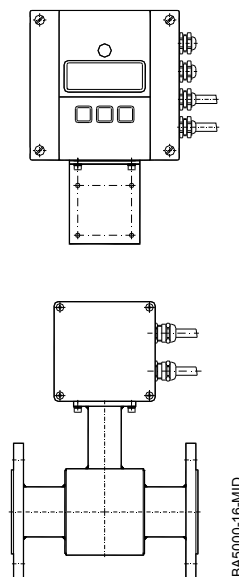

3.2.6 Grounding and potential equalization

In order to obtain an accurate measurement, detector and fluid need to be on the same electric potential.

If flange or intermediate flange versions with additional grounding electrode are used, grounding is provided by the connected pipeline.

- Caution:*
- *In case of a type with flange a connection cable (min. 4 mm²) between grounding screw on the meter's flange to the counterflange is to be used in addition to the fixing screws. Verify that a perfect electric connection is provided.*
 - *Color or corrosion on the counterflange may have a negative effect on the electric connection.*



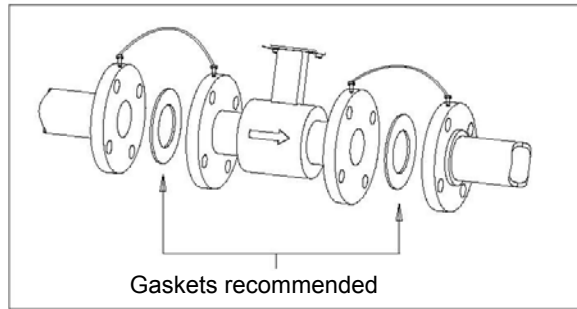

3.2.7 Plastic or lined pipelines

If non-conductive pipelines or pipelines lined with non-conductive material are used, install an additional grounding electrode or grounding rings between the flanges. Grounding rings are installed like gaskets between the flanges and are connected with a grounding cable to the meter.

Caution:

- *When grounding rings are used, please make sure that the material is resistant to corrosion. If aggressive fluids are measured, use grounding electrodes.*

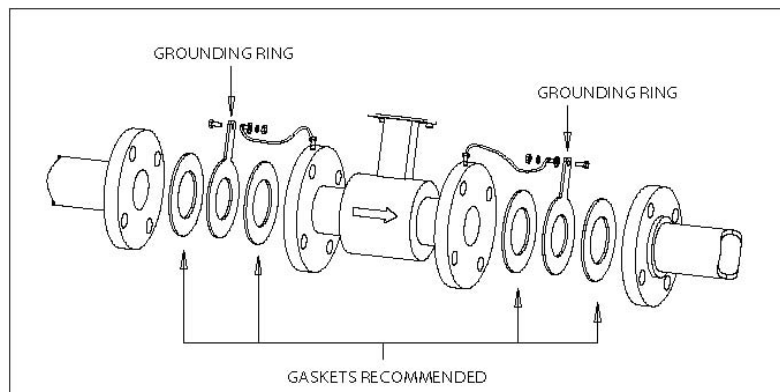

3.2.8 Pipelines with cathodic protection

As for pipelines with cathodic protection, install meter potential-free. No electric connection from the meter to the pipeline system may exist and power supply is to be provided via isolating transformer.

Caution:

- *Use grounding electrodes (grounding rings also need to be installed isolated from the pipeline system).*
- *Observe national rules in respect of a potential-free installation.*

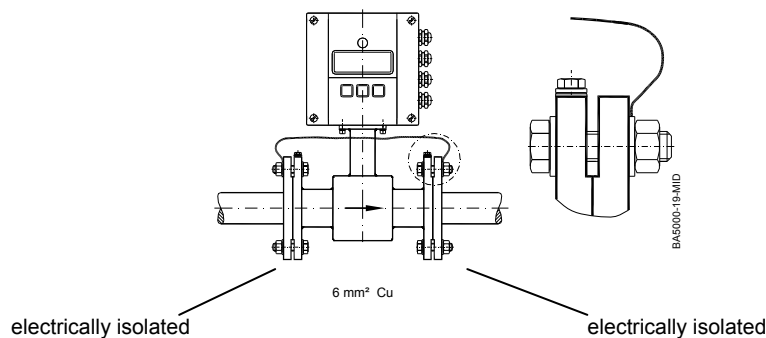

3.2.9 Electrically disturbed environment

If the pipe material is in an electrically disturbed environment or if metallic pipelines that are not grounded are used, we recommend a grounding as shown in the following picture in order to assure that measurement is not influenced.

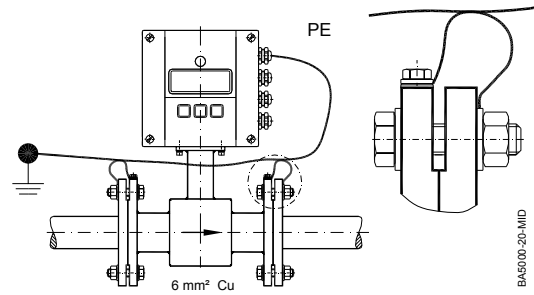

4. Electrical connections

- Caution:**
- For the 4 x M20 cable inlets, only use flexible electric cables.
 - Use separate cable inlets for auxiliary power, signal and input/output cables.
 - For the signal cables, only use shielded cables. The cable entry should be done as shown in the picture below.

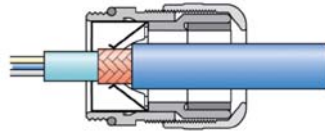

Opening the B-MAG I M5000 cover

The B-MAG I M5000 amplifier's design allows opening the cover without completely removing it.

Follow these steps:

1. Completely remove the top two screws from the amplifier using a blade/slotted screwdriver.

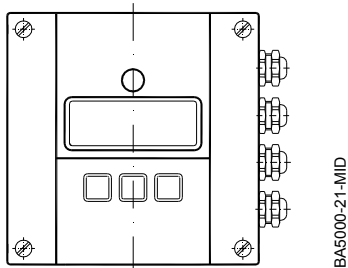

2. Loosen both of the bottom screws so that the round head of each screw clears the top face of the cover.



3. Lift the cover and pull the cover down to the open position.



4.1 Power

B-MAG I M5000 can be powered with:

- Battery only (2 D-cells or 4 D-cells)
- 100 – 240 VAC (with battery back-up)
- 9 – 36 VDC (with battery back-up)

Should you use battery power only, please read chapter 4.1.1. Should you use a device with AC or DC power supply, please read chapter 4.1.2.

4.1.1 Battery

Normally delivered batteries:

2 D-cells battery pack for the sizes DN 15 (1/2") to DN 150 (6"). 4 D-cells battery pack (extended version) for the sizes DN 200 (8") to DN 600 (24").



The meter is delivered with unplugged battery and must be plugged in. The connection jack is below the sign „BAT“ (red = +).

Note:

- The battery life time strongly depends on ambient temperature, sampling rate and how many outputs used.

Standard battery pack	
Sampling	Expected battery life
0.25 s	3 months
4 s	4 years
8 s	8 years
15 s	10 years

These calculations are for a standard battery pack, with two D-size batteries, with communication and outputs OFF, at an ambient temperature of 25° C (77° F).

Battery replacement

1. Go to menu (MainMenu>Misc>Battery>Change) and select the capacity of the battery pack which should be installed (see label on the battery pack 19 Ah,38 Ah or 70 Ah). After the selection of the correct battery capacity and quit by button **E**, the display freezes (no reaction by pressing any button).
2. Open the cover as described in chapter 4.
3. Remove all connectors (detector and outputs)



4. Open all 4 screws of the main board, remove the circuit board and disconnect the old battery.
5. Open the screws of the battery cover and remove it.
6. Remove old battery and wait about 2 minutes before replace it by a new one (LCD display should be off).
7. Replace battery cover, plug the battery connector to the back of the main board and replace the circuit board.
8. Replace all the plugs
9. Close the cover tight
10. Check time and date (MainMenu>Misc>Time and MainMenu>Misc>Date TMJ)
11. Check capacity of battery (MainMenu>Misc>Capacity). First value is the already used capacity which should be 0.0. Second value is the capacity of the battery pack.

4.1.2 Battery backup

- Attention:*
- Do not install the meter under voltage
 - Respect national directives in force
 - Respect directives of the type plate (voltage and frequency)

Connection of the power supply according to the terminal marking.

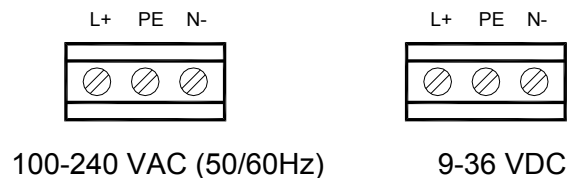

The safety fuse is soldered on the electronic board (1.6 A slow)

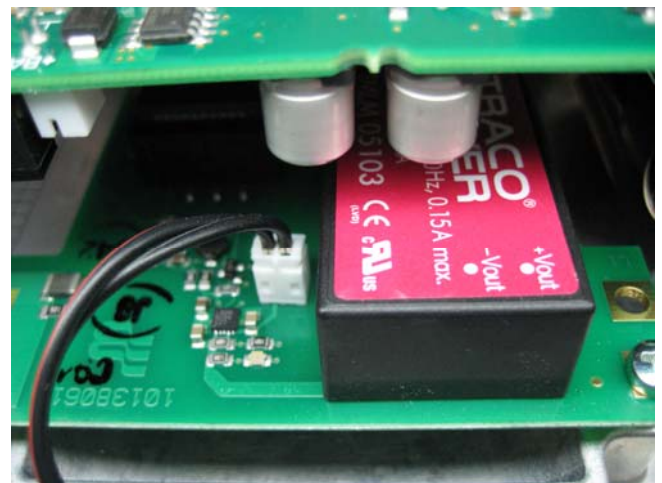
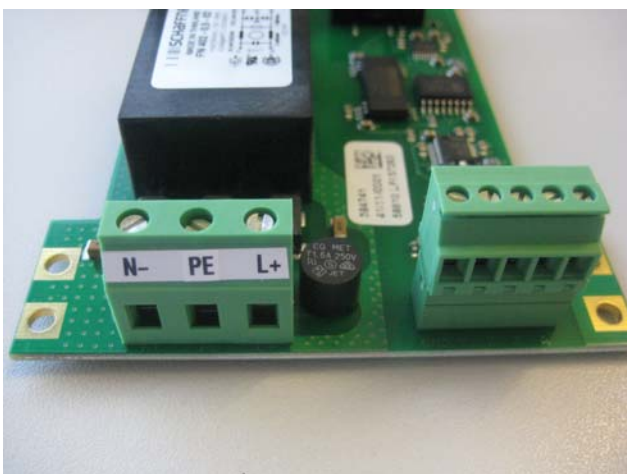

The meter is delivered with unplugged battery and must be plugged in.
The connection socket is on the power supply board. See picture.



4.2 Separate version

4.2.1 Connection on the amplifier

1. Open the cover of the amplifier.
2. Push both cables through two different cable glands (see picture above).
3. The cable entry should be done as shown in the picture below.

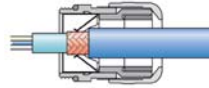
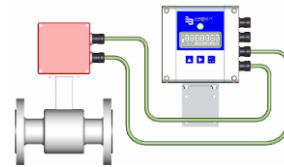

4. Connect the cables to the corresponding plugs on the left side of the board (see picture below).

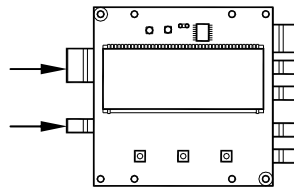

5. Close cover tight.

4.2.2 Connection on the detector

1. Loosen fixing screws of the connection cover and remove cover.
2. Push both cables through two different cable glands.
3. Connect the cables to the corresponding plugs on the left side of the board (see picture below).

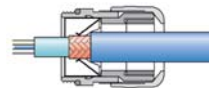

4. Connection as shown in the picture below.

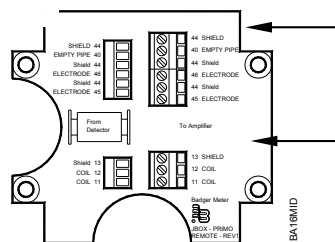

5. Close junction box cover again firmly.



Terminal		Description	Wire color
11	C1	Coil C1	Red/Brown
12	C2	Coil C2	Blue/White
13		n.a.	
40	EP	Empty pipe detection	Pink
44*	⊥	Shielding electrode	Green
44*	⊥	Shielding electrode	Green
45	E1	Electrode E1	White
46	E2	Electrode E2	Black

*) Connections with number 44 are on the same potential.

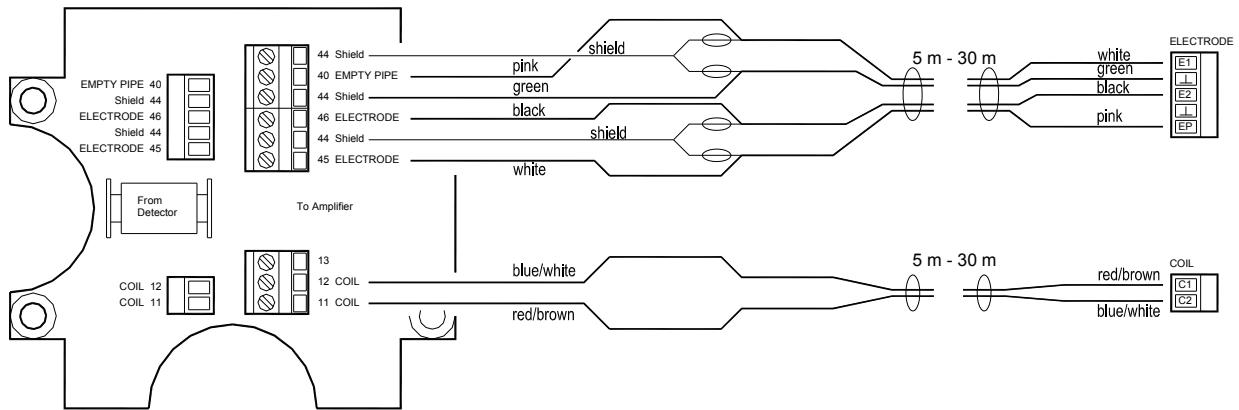

BA5000-26e-MID



4.2.3 Signal cable specification

- Note:
- Only use signal cables delivered by Badger Meter or corresponding cable in accordance with the following specification.
 - Take max. signal cable length between detector and amplifier into account (keep distance as low as possible).

Electrode cable		
Distance	Type	Capacity
Max. 30 m	RGB DY 5 x Kx 0,4/1,8	60 nF/km
Temperature range -10 bis +80 °C		

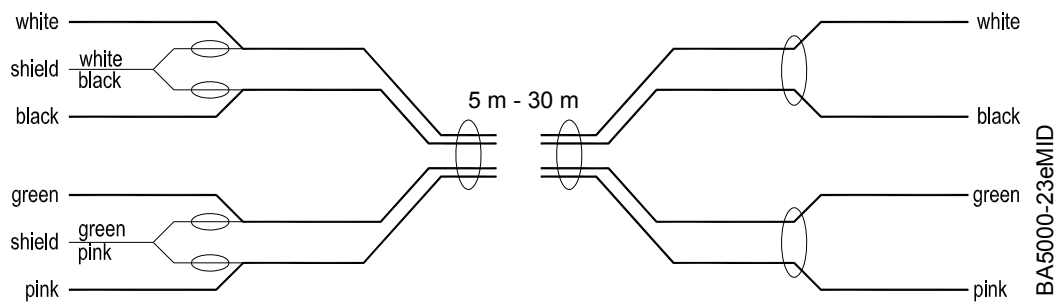

Coil cable		
Distance	Type	Resistance
Max. 30 m	1 x (2 x 0,34 mm ²)	< 115 Ω/km
PVC cable Typ Li2YCY (TP)		
Temperature range -5 bis +70 °C		

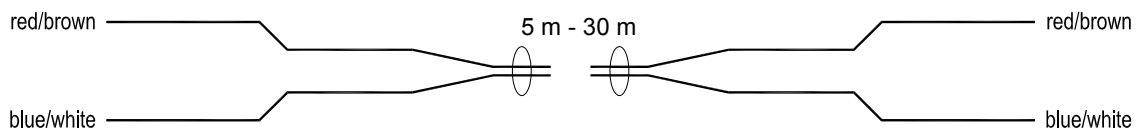

4.3 Configuring input/output (I/O)

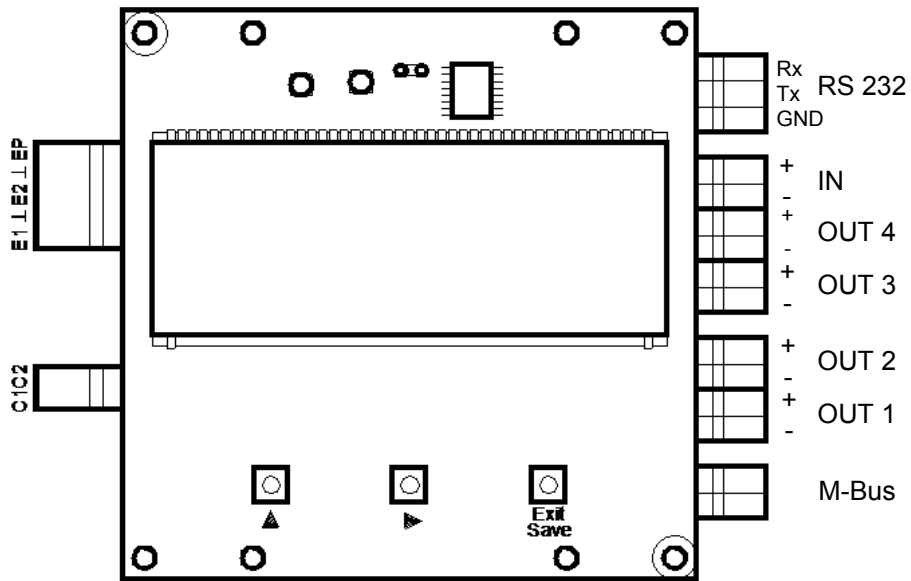

Input/Output	Description	Terminal
1	Open collector, passive max. 30 VDC, 20 mA max. frequency 100 Hz	OUT1 (+) and (-)
2	Open collector, passive max. 30 VDC, 20 mA max. frequency 100 Hz	OUT2 (+) and (-)
3	Open collector, passive max. 30 VDC, 20 mA max. frequency 100 Hz	OUT3 (+) and (-)
4	Open collector, passive max. 30 VDC, 20 mA max. frequency 100 Hz	OUT4 (+) and (-)
RS 232	ModBus [®] RTU	← RxD → TxD ⊥ GND
IN	Digital input 3-35 VDC	IN (+) and (-)
M-BUS	M-Bus interface	No polarity

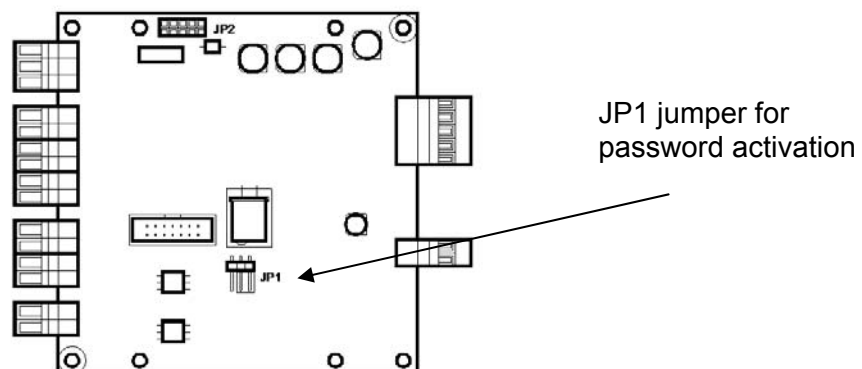

5. Parametering

The LCD display of the meter is composed of 2 lines and 3 areas. Actual flow rate and single totalisator values (through scrolling with key ▲) are displayed on line 1 (area 1). Symbols for the battery status, hardware back-up, bidirectional measurement, errors and empty pipe detection are displayed on the left side of the second line (area 2). The unit, various totalisators and single menu points are displayed on the right side of the second line (area 3).

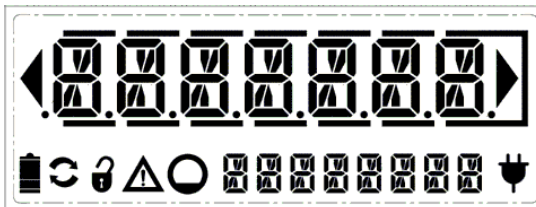

Definition of the symbols:

- Battery status (OK, Replacement of battery recommended, No measurement)
- Communication interface is activated (RS232, IrDA, M-Bus)
- Password protection is deactivated
- Error message
- Empty pipe detection
- Battery back-up (external power supply)

Parametering of the meter can be done with the following 3 keys: ▲,▶ and E

To access the measuring mode for parametering, please press the key ▲ as long as necessary until “Menue” is displayed on the second line.

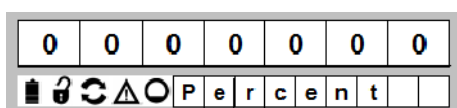

Select Programming

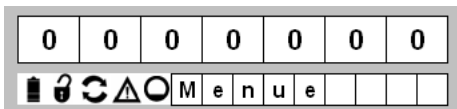

Now press key ▶ to select this menu point.

In the menu structure, press key ▲ to move from one menu point to the other one. Press key ▶ to select the menu point.

To select parameters or values from a list in a menu point, press key ▲ until the requested parameter or value is displayed and confirm with key E.

The first character flashes when you enter a value; press the key ▲ to change the figure. Once you have changed the desired figure, move to the next figure with the key ▶. Confirm the new value with key E.



Access to the various menus can be monitored via three configurable access levels: Administrator, Service and User.

The access rights are symbolized as follows:



Administrator



Service



User

Please see chapter „Passwords“ to configure the access levels. No passwords are entered before leaving the factory.



If you do not press any key during 60 seconds while being in the parametering menu, the meter automatically goes back to the measuring display (only in secured mode “Locked”).







6. Main menu

Following menu structure is available:





- Meter setup
- Measure
- Outputs
- Communication
- Misc
- Info
- PIN

Meter Setup		
Calibration	Diameter [Diameter] 	This figure is used for setting pipe's diameter (size). Several sizes from DN 15 to DN 600 can be set. Note: Pipe diameter is set at the factory. Changes of size have an impact on meter's accuracy.
	Detector Factor [Det Fact] 	This parameter is set at the factory. This factor compensates for accuracy error as a result of the installed detector. If accuracy adjustment of the meter is required, please refer to the scale factor. In the event the amplifier is replaced, this parameter must be reprogrammed with the original detector factor.
	Detector Offset [Det Zero] 	This parameter is set at the factory. This factor compensates for accuracy error as a result of the installed detector. If accuracy adjustment of the meter is required, please refer to the scale factor.
	Amplifier Factor [Amp Fact] Read only	This parameter is set at the factory. This factor compensates for accuracy error as a result of the installed amplifier.
	Coil Current [Coil Cur] Read only	This parameter is set at the factory. This factor compensates for accuracy error as a result of the installed amplifier.





Meter Setup		
Scale Factor [scale] 	<p>Changing the scale factor lets you adjust the meter's accuracy without disturbing parameters set by the factory – You can tune the meter to meet changing application requirements.</p> <p>Possible adjustment from 0,901 ...1,0999.</p>	
Power Line Frequency [Freq HZ] 	<p>This parameter is set at the factory. This parameter provides measuring immunity to industrial noise from a power supply feed.</p>	
Period [Period s] 	<p>This parameter configures the frequency from 0 second to 63 seconds of sampled measurements. The adjustment can be done in steps of 1 second. The value 0 is only used for calibration (4 measurements per second).</p> <p>Note: This parameter will affect battery performance. As shorter the measuring period as shorter the battery life time.</p>	
Empty Pipe Detection	Empty Pipe [On Off] 	<p>Fluid monitoring shows if measuring pipe has only partly been filled with liquid. Monitoring can be switched on or off.</p> <p>Note: On request, fluid monitoring can be adjusted to fluid's conductivity or to cable length.</p>
	Threshold [Threshold] 	<p>This parameter is set at the factory and adjusted to the conductivity of normal water.</p>
	Measuring [Measure] Read only	<p>Measures the real empty pipe value.</p>





Measure																																													
<p>Flow Unit [Flow Unit]</p> 	<p>Flow Units let you select among the flow units mentioned below. Flow units are automatically converted into the selected unit. Changing this parameter readjusts the full scale flow parameter.</p> <table border="1" style="width: 100%; border-collapse: collapse;"> <thead> <tr> <th></th> <th style="text-align: center;">Flow Unit</th> <th></th> <th style="text-align: center;">Flow Unit</th> </tr> </thead> <tbody> <tr> <td>LPS</td> <td>Liter/Second</td> <td>GPM</td> <td>Gallons/Minute</td> </tr> <tr> <td>LPM</td> <td>Liter/Minute</td> <td>GPH</td> <td>Gallons/Hour</td> </tr> <tr> <td>LPH</td> <td>Liter/Hour</td> <td>MGD</td> <td>MegaGallon/Da</td> </tr> <tr> <td>M3S</td> <td>CubicMeter/Secon</td> <td>IGS</td> <td>UKG/Second</td> </tr> <tr> <td>M3M</td> <td>CubicMeter/Minut</td> <td>IGM</td> <td>UKG/Minute</td> </tr> <tr> <td>M3H</td> <td>CubicMeter/Hour</td> <td>IGH</td> <td>UKG/Hour</td> </tr> <tr> <td>F3S</td> <td>Cubic Feet/Sec.</td> <td>OPM</td> <td>Ounce/Minute</td> </tr> <tr> <td>F3M</td> <td>Cubic Feet/Minute</td> <td>BPM</td> <td>Barrel/Minute</td> </tr> <tr> <td>F3H</td> <td>Cubic Feet/Hour</td> <td>--</td> <td>--</td> </tr> <tr> <td>GPS</td> <td>Gallons/Second</td> <td>--</td> <td>--</td> </tr> </tbody> </table>		Flow Unit		Flow Unit	LPS	Liter/Second	GPM	Gallons/Minute	LPM	Liter/Minute	GPH	Gallons/Hour	LPH	Liter/Hour	MGD	MegaGallon/Da	M3S	CubicMeter/Secon	IGS	UKG/Second	M3M	CubicMeter/Minut	IGM	UKG/Minute	M3H	CubicMeter/Hour	IGH	UKG/Hour	F3S	Cubic Feet/Sec.	OPM	Ounce/Minute	F3M	Cubic Feet/Minute	BPM	Barrel/Minute	F3H	Cubic Feet/Hour	--	--	GPS	Gallons/Second	--	--
	Flow Unit		Flow Unit																																										
LPS	Liter/Second	GPM	Gallons/Minute																																										
LPM	Liter/Minute	GPH	Gallons/Hour																																										
LPH	Liter/Hour	MGD	MegaGallon/Da																																										
M3S	CubicMeter/Secon	IGS	UKG/Second																																										
M3M	CubicMeter/Minut	IGM	UKG/Minute																																										
M3H	CubicMeter/Hour	IGH	UKG/Hour																																										
F3S	Cubic Feet/Sec.	OPM	Ounce/Minute																																										
F3M	Cubic Feet/Minute	BPM	Barrel/Minute																																										
F3H	Cubic Feet/Hour	--	--																																										
GPS	Gallons/Second	--	--																																										
<p>Totalizer Unit [Tot Unit]</p> 	<p>This parameter establishes the units of measure for the totalizers.</p> <table border="1" style="width: 100%; border-collapse: collapse;"> <thead> <tr> <th></th> <th style="text-align: center;">Totalizer Unit</th> <th></th> <th style="text-align: center;">Totalizer Unit</th> </tr> </thead> <tbody> <tr> <td>L</td> <td>Liter</td> <td>MG</td> <td>MegaGallons</td> </tr> <tr> <td>HL</td> <td>HectoLiter</td> <td>UKG</td> <td>Imperial Gallons</td> </tr> <tr> <td>M^3</td> <td>CubicMeter</td> <td>Oz</td> <td>Fluid Ounces</td> </tr> <tr> <td>Cft</td> <td>Cubic Feet</td> <td>Aft</td> <td>Acre Feet</td> </tr> <tr> <td>USG</td> <td>U.S. Gallons</td> <td>BBL</td> <td>Barrel</td> </tr> </tbody> </table>		Totalizer Unit		Totalizer Unit	L	Liter	MG	MegaGallons	HL	HectoLiter	UKG	Imperial Gallons	M^3	CubicMeter	Oz	Fluid Ounces	Cft	Cubic Feet	Aft	Acre Feet	USG	U.S. Gallons	BBL	Barrel																				
	Totalizer Unit		Totalizer Unit																																										
L	Liter	MG	MegaGallons																																										
HL	HectoLiter	UKG	Imperial Gallons																																										
M^3	CubicMeter	Oz	Fluid Ounces																																										
Cft	Cubic Feet	Aft	Acre Feet																																										
USG	U.S. Gallons	BBL	Barrel																																										
<p>Full Scale [Full Sca]</p> 	<p>This parameter sets the maximum flow the system is expected to measure. This parameter has influence on other system parameters like “Low flow cutoff” and “High/Low Alarm”</p> <p>Change the full scale flow based on the meter size and the application’s requirements. Verify that the full scale flow falls within the meter’s suggested flow range limits 0.1 to 10 m/s (0.328 to 32.8 FPS).</p> <p>The full scale flow is valid for both flow directions.</p> <p>Note: If the flow rate exceeds the full scale setting of more than 25% a FLOW_OVERLOAD_WARNING message indicates that the configured full scale range has been exceeded. However, the meter will continue to measure.</p>																																												
<p>Low Flow Cutoff [Cut Off]</p> 	<p>Low Flow Cutoff defines the threshold at which flow measurement will be forced to zero. The cutoff value can be from 0 % to 9.9 % of the full scale flow. Increasing the threshold will help prevent false reading during “no flow” conditions possible caused by vibrations or liquid fluctuations.</p>																																												



Measure	
<p>Flow direction [Bi-directional]</p> 	<p>Flow direction lets you set the meter to measure forward flow only (uni-directional) or both forward and reverse flow (bidirectional).</p> <p>Unidirectional means that the flow is totalized in only one direction. The flow direction is indicated by the arrow printed on the detector label. In this mode, the two totalizers T1/T2 can be used as overall totalizer (T2) and resettable day counter (T1). If measured in reverse direction no flow is indicated on the display and outputs.</p> <p>Bidirectional means the flow is totalized in both directions. The totalizer T1+/T2+ registers forward flow and the totalizer T1-/T2- totalizes in reverse flow direction. The net totalizer TN1/T2 registers total flow and shows the difference between T+ and T-. All totalizers T1+, T1- and TN1 are resettable.</p> <p>A change of the flow direction can be signaled by the digital outputs.</p>
<p>T1 Reset [T1]</p> 	<p>The totalizers T1, T1+ / T1- and TN1 are resettable by pressing the button E.</p> <p><u>Note:</u> If the meter is used as a water meter according the European directive 2004/22/EC (MID MI-001) or OIML R49 the totalizer T1 is NOT resettable.</p>
<p>Median filter [Median]</p>	<p>This filter is a non-linear digital filtering used to remove noise.</p>
<p>Filter display [FiltDisp]</p>	<p>Damping for the flow rate at the display.</p>



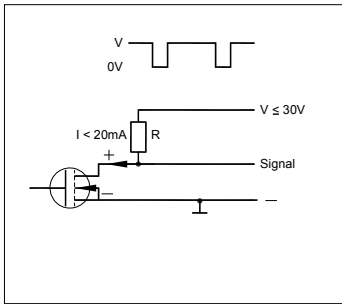
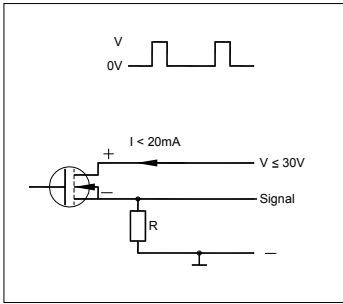

Outputs / Input	
<p>Simulation [Simulat]</p> 	<p>Flow simulation provides output simulation based on a percentage of the full scale flow. Simulation will not accumulate the totalizers. The range of simulation includes -100% to 100% of the full scale flow.</p> <p>The Flow Simulation parameter lets you set the range of simulation in increments of 50 (OFF, 0, 50, 100, -50, -100).</p>
<p>Digital Input [Input]</p> 	<p>Digital input lets you reset totalizer T1 or interrupt flow measurement.</p> <p>Input switching is provided by applying an external voltage of 3 to 35 VDC.</p> <p>Use a “normally open” contact for operating.</p>
<p>Digital Outputs [Outputs]</p>	<p>You can configure the functional operation of the 4 digital outputs in the sub-menu “Functional operation“. You can select e.g “forward pulse” for the digital output and define the pulses per totalizer unit via “pulse scale”.</p> <p>Note: It is recommended to switch off the outputs in the menu “Output function” if not used. This increase the battery life time.</p> <p>Digital outputs 1 to 4</p> <p>All the outputs are operated as open collector passively with max. 30 VDC/20 mA and a max. frequency of 100 Hz.</p> <p><u>Wiring diagramms</u></p> <div style="display: flex; justify-content: space-around;"> <div style="border: 1px solid black; padding: 5px; width: 45%;">  </div> <div style="border: 1px solid black; padding: 5px; width: 45%;">  </div> </div>



Outputs																																																			
<p>Function</p> <p>[Out1 Func]</p> <p>[Out2 Func]</p> <p>[Out3 Func]</p> <p>[Out4 Func]</p> <p> S</p>	<p>The following functions can be selected for the outputs 1 to 4:</p> <table border="1"> <thead> <tr> <th>Function</th> <th>Dig1</th> <th>Dig2</th> <th>Dig3</th> <th>Dig4</th> </tr> </thead> <tbody> <tr> <td>Inactive</td> <td>X</td> <td>X</td> <td>X</td> <td>X</td> </tr> <tr> <td>Forward pulse</td> <td>X</td> <td></td> <td></td> <td></td> </tr> <tr> <td>Reverse pulse</td> <td></td> <td>X</td> <td></td> <td></td> </tr> <tr> <td>Test</td> <td>X</td> <td>X</td> <td>X</td> <td>X</td> </tr> <tr> <td>Flow set point</td> <td>X</td> <td>X</td> <td>X</td> <td>X</td> </tr> <tr> <td>Empty pipe alarm</td> <td>X</td> <td>X</td> <td>X</td> <td>X</td> </tr> <tr> <td>Flow direction</td> <td></td> <td></td> <td>X</td> <td></td> </tr> <tr> <td>Error alarm</td> <td>X</td> <td>X</td> <td>X</td> <td>X</td> </tr> <tr> <td>ADE</td> <td></td> <td></td> <td></td> <td>X</td> </tr> </tbody> </table> <p>Inactive [Off] means digital output is switched off. It is recommended to switch off the outputs in the menu “Output function” if not used. This increase the battery life time.</p> <p>Forward pulse [Forward] generates pulses during forward flow conditions.</p> <p>Reverse pulse [Reverse] generates pulses during reverse flow conditions.</p> <p>Test [Test] The output will be triggered.</p> <p>Flow set point [MinMax] provides indication when flow rate exceeds thresholds defined by flow set points.</p> <p>Empty pipe alarm [Empty] provides indication when pipe is empty.</p> <p>Flow direction [Direct] provides indication on current flow direction.</p> <p>Error alarm [ErAlarm] provides indication when meter has error condition.</p> <p>ADE [ADE] “Absolute Digital Encoder” for remote meter reading using ASCII communication protocol.</p> <p>Loopback [Loopbck]</p>	Function	Dig1	Dig2	Dig3	Dig4	Inactive	X	X	X	X	Forward pulse	X				Reverse pulse		X			Test	X	X	X	X	Flow set point	X	X	X	X	Empty pipe alarm	X	X	X	X	Flow direction			X		Error alarm	X	X	X	X	ADE				X
Function	Dig1	Dig2	Dig3	Dig4																																															
Inactive	X	X	X	X																																															
Forward pulse	X																																																		
Reverse pulse		X																																																	
Test	X	X	X	X																																															
Flow set point	X	X	X	X																																															
Empty pipe alarm	X	X	X	X																																															
Flow direction			X																																																
Error alarm	X	X	X	X																																															
ADE				X																																															







Outputs	
<p>Pulse/Unit [Pulse/Unit]</p> 	<p>The Pulses/Unit parameter lets you set how many pulses per unit of measure will be transmitted. The configurable range is from 0.001 to 9999 pulses/volume unit, however the max. output frequency of 100 pulses/sec. (100 HZ) must not be exceeded.</p> <p>This parameter must be considered with the Pulse Width and Full Scale Flow parameters. The maximum pulse frequency is 100 Hz. The frequency is correlated with the flow rate. Violation of output frequency limits will generate a PULSE_OVERLOAD_WARNING.</p>
<p>Width [Width ms]</p> 	<p>This parameter establishes the ON duration of the transmitted pulse. The configurable range is from 0 to 500 ms.</p> <ul style="list-style-type: none"> • Non-zero pulse width configuration – the OFF duration of the transmitted pulse is dependent on flow rate. The OFF duration is to be at least the configured ON duration. At full scale flow, the ON duration equals the OFF duration. The maximum configurable output frequency is limited to 100 Hz. • The duty cycle of the transmitted pulse is at 50% of the output frequencies greater than 1 Hz. <p>This parameter must be considered with the Pulse/Unit and Full Scale Flow parameters. The maximum pulse frequency is 100 Hz. The frequency is correlated with the flow rate. Violation of output frequency limits will generate a PULSE_OVERLOAD_WARNING.</p>
<p>Flow Set Point [Set Min] [Set Max]</p> 	<p>The Flow Set Point (min, max) establishes - as a percentage of full scale flow - the threshold at which the output alarm will be activated. You can freely select thresholds in 1% steps. Flow rates below/above the threshold will activate the output alarm.</p>









Outputs	
<p>Output Mode [Out 1 Type] [Out 2 Type] [Out 3 Type] [Out 4 Type]</p> 	<p>This parameter lets you set the output switch to normally open or normally closed. If normally open is selected, the output switch is open (no current) when the output is inactive, and closed (current flows) when the output is active.</p> <p>If normally closed is selected, the output switch is closed (current flows) when the output is inactive, and open (no current) when the output is active.</p>



Communication		
Communication [Communic]	Adjustments of the communication ports (ModBus® RTU / M-Bus)	
	<p>Interface [Interface]</p> 	<p>This parameter provides communication port configuration.</p> <ul style="list-style-type: none"> • Off • Serial (Terminal) • IrDA (Infrared port) • M-Bus
	<p>Serial [Serial]</p> 	<p>Baud Rate [Baudrate] This parameter sets the baud rate. Following baud rates are supported:</p> <ul style="list-style-type: none"> • 9600 • 1200 • 2400 <p>Parity [Parity] This parameter sets the parity. Following baud rates are supported:</p> <ul style="list-style-type: none"> • Even • Odd • Mark
	<p>Modbus [Modbus]</p> 	<p>Address [Address] This parameter configures the ModBus® address in the range from 1 to 247.</p>
	<p>M-Bus [M-Bus]</p> 	<p>Address [Address] This parameter configures the M-Bus® address in the range from 1 to 247.</p>
	<p>ADE</p> 	<p>Protocol [Protocol] V1 or V2 Dial [Dial] 4 to 9 Resolution [Resolution] 0,0001 to 10000</p>







Miscellaneous		
Misc [Misc]	Voltage [Voltage] Read only	Displays the current battery voltage.
	Capacity [Bat Ah] Read only	Displays the current battery capacity (0/38V to 38/38V). Note: A new battery should be at or near a 0/38 reading.
	Life Time [LifeTime] Read only	Displays the remaining battery life time in years depending on the currently selected parameters. Note: Battery life time is mainly influenced by the excitation frequency (period) and selected communication interfaces.
	Language [Language] 	This parameter allows changing the current language. Following languages are supported: <ul style="list-style-type: none"> • English • German • Czech • Spanish • French • Russian
	Date [Date DMY] 	A real-time clock. The month, date and year must be reprogrammed after the battery is replaced.
	Time [Time] 	A real-time clock. The time must be reprogrammed after the battery is replaced.
	EEPROM [EEPROM] 	Format the EEPROM to erase all log files. Totalizers and configuration remain unaffected during a format.
	Battery [Battery] 	Saves totalizers to non-volatile memory in preparation for battery replacement.
	Restart [Restart] 	Provides the ability to reset the meter electronics.





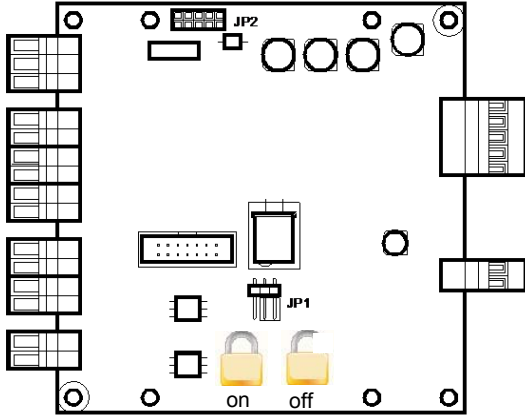

Miscellaneous		
	HDD Free [HDD Free] Read only 	Indicate free flash memory space.
Polarity [Polar V] Read only	Measured electrode polarizing voltage (just for service purpose).	
Datalogger [DataLog]	The logging period can be adjusted to following values: 1 min / 15 min / 1 h / 6 h / 12 h / 24h	
LCD Test [LCD Test]	After pressing E, all display segments appear for about 2 seconds.	

Information		
Information [Info] Read only	Serial number [SerNum]	Serial number of the electronic board.
	Software version [Version]	Software version of the device.
	Software Date [Compilat]	Date of the software version.
	OTP CRC [OPT CRC]	Checksum of software update
	APP CRC [APP CRC]	Checksum of application
	OIML mode [OIML mode]	If the meter is used as a water meter according to OIML R49 or MID, the mode have to be ON. In this case, all parameters “read only”.



Password	
Password [Pwd]	<p>The different menus and parameterings can be secured via three password levels.</p> <ul style="list-style-type: none"> • Administrator PIN  • Service PIN  • User PIN  <p>The password protection is a 6-digit PIN which is parametered on [000000] and deactivated at the factory.</p> <p>Press the jumper on the back side of the electronic board into the position „On“ to activate the password protection.</p> <div style="text-align: center;">  </div> <p>Enter a figure (PIN) in the [User],[Service] and [Admin] menu and activate the password protection [active] = On.</p> <p>Once the password protection has been activated, please enter your PIN under Login; the  symbol (lock open) appears. The PIN grants you access to either Administrator, Service or User level with the respective access rights (marked with A, S and B in the manual). You can now move to the menu and enter your parameters.</p> <p>Without login, you can read all parameters, but cannot change them.</p> <p>To log out, go back to „login“ and press the ► key. You see [000000]; press the E key or enter an incorrect PIN; the open lock  disappears from the display</p> <p><u>Note:</u> If the meter is used as a water meter according to the European directive 2004/22/EC (MID MI-001) or OIML R49, all parameters are locked and only readable. In this case, the “Password” feature above is not feasible.</p>



Password	
Security [PIN] 	<ul style="list-style-type: none"> • ON (requires PIN configuration) • OFF
User 	User logged in with this PIN will have access to all user-levels. Users at this level do not have access to Service or Admin functions.
Service 	User logged in with this PIN will have access to both service and user-level procedures. User at this level will not have access to administrative functions.
Admin 	User logged in with this PIN will have access to all procedures. User at this level will have full access to the meter.
Rand	This function generates a random number which is used when a PIN is lost.
Emergenc	Enter here the Master PIN you got from the Badger Meter Service to unlock the meter in case of a lost Admin PIN.

Faults	
Faults	Error list display shows how often an error occurs.



7. Troubleshooting

Error messages are shown on the local display via icons or in letters. The 4 digital outputs can be used to display any error alarm on a external device.

Errors & Warnings:

- MEASURE_TIMEOUT
Measurement was not completed in 250ms
- COMMON_MODE_VOLTAGE_OVERLOAD
Common mode voltage is smaller than -2.0V or larger than +4.1V.
- EMPTY_PIPE_WARNING
Measured impedance between the empty pipe electrode and the ground exceeded the set value.
- PULSE_OVERLOAD_WARNING
Overflow occurred on the flow output
- FLOW_OVERLOAD_WARNING
Flow exceeded the full scale of more than 25%.
- LOW_POWER_WARNING
Battery voltage is smaller than 3.0V. Consider replacing the battery upon reading this warning.
- EEPROM_ERROR
Configuration file is missing.
- CONFIG_ERROR
Configuration file is corrupted.
- PREAMPLIFIER_OVERLOAD
Input voltage exceeded the limits. Maximum polarization is $\pm 227\text{mV}$; maximum power line noise is 10.6mV; maximum useful signal is 10.7mV.
- Coil
Circuit of the coils is interrupted

When one of the errors occurs, the meter stops measuring until the error disappears; then the meter continues to measure.



Some frequently occurring errors are listed in the following:

Other error	Possible cause	Recommended action
Meter does not function	<ul style="list-style-type: none"> ▪ Flat battery or not connected 	<ul style="list-style-type: none"> ▪ Check battery connection ▪ Change battery
Fluid is flowing, however display shows zero	<ul style="list-style-type: none"> ▪ Signal cable is not connected or connection is interrupted ▪ Detector installed opposite to forward flow direction (see arrow on type plate) ▪ Connection cable for coils or electrodes mixed-up 	<ul style="list-style-type: none"> ▪ Check signal cable ▪ Turn detector by 180° ▪ Check connection cable
Inaccurate measurement	<ul style="list-style-type: none"> ▪ Wrong parameters ▪ Pipe not completely full ▪ None or no sufficient grounding 	<ul style="list-style-type: none"> ▪ Check parameters (detector, amplifier and size) as per annexed data sheet ▪ Check if measuring pipe completely full ▪ Improve grounding



7.1 Replace meter's electronics

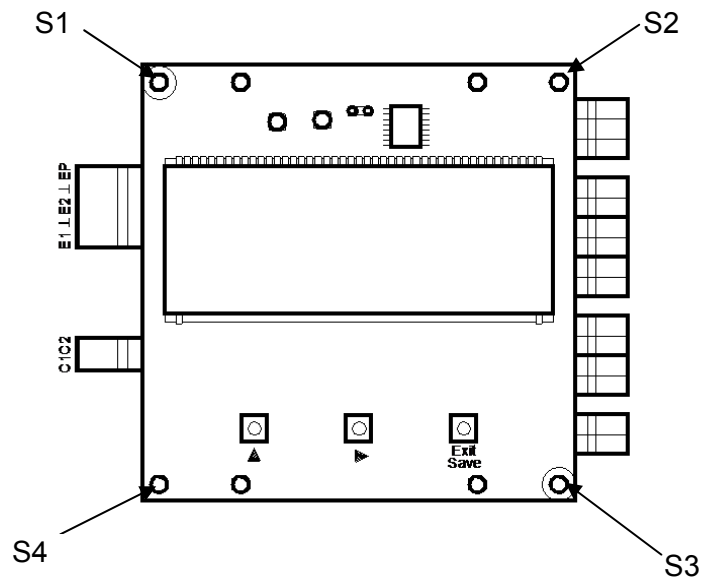

1. Pull out electrode and coil plugs. Loosen screws S1-S4 and take out circuit board.
2. Insert new circuit board and fix it by fastening the screws S1-S4. Plug again the two plugs.
3. If necessary, configure new circuit board related to the available meter (detector, size).

8. Technical data

8.1 Detector type VI

Size	DN 15 – 600 (1/4" ...56")		
Process connection	Flange: DIN, ANSI, JIS, AWWA, etc.		
Nominal pressure	Up to PN 100		
Protection class	IP67, optional IP68		
Min. conductivity	≥20 µS/cm		
Liner materials	Hard rubber	from DN 25	0°C up to +80°C
	PTFE	DN 15 – 20	-40°C up to +150°C
Electrodes materials	Hastelloy C (Standard), Tantalum Platinum / Gold plated, Platinum / Rhodium		
Housing	Steel / Optional stainless steel		
Lay length	DN 15 – 20	170 mm	
	DN 25 – 50	225 mm	
	DN 65 – 100	280 mm	
	DN 125 – 200	400 mm	
	DN 250 – 350	500 mm	
	DN 400 – 600	600 mm	

Flange process connection
B-MAG I M5000 remote version

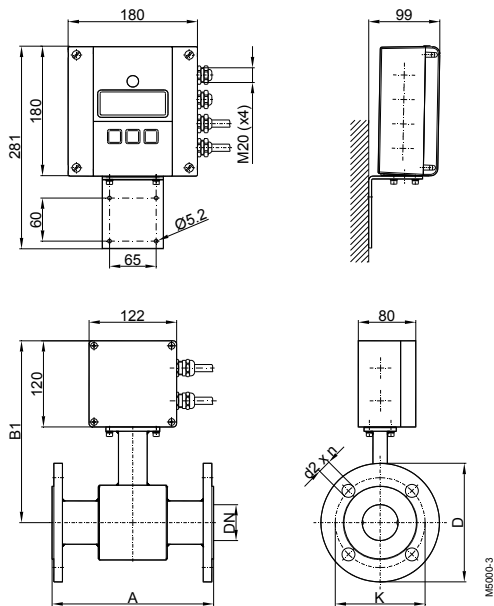

Flange process connection
B-MAG I M5000 mounted version

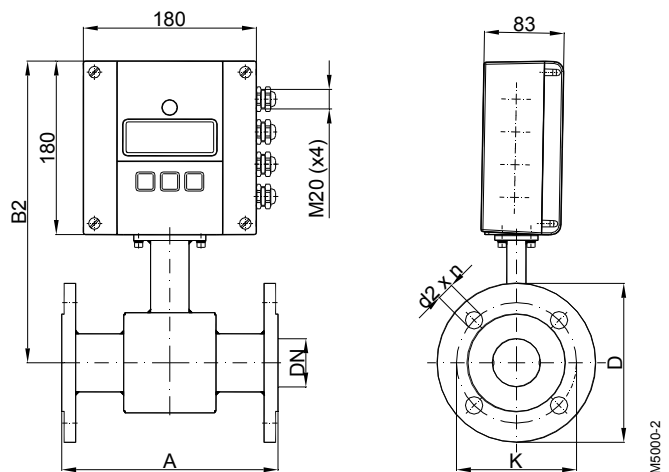

DN		A Std*	A ISO**	B1	B2	with ANSI-flanges			with DIN-flanges		
						∅ D	∅ K	∅ d2xn	∅ D	∅ K	∅ d2xn
15	1/2"	170	200	238	298	88,9	60,3	15,9 x 4	95	65	14 x 4
20	3/4"	170	200	238	298	98,4	69,8	15,9 x 4	105	75	14 x 4
25	1"	225	200	238	298	107,9	79,4	15,9 x 4	115	85	14 x 4
32	1 1/4"	225	200	253	313	117,5	88,9	15,9 x 4	140	100	18 x 4
40	1 1/2"	225	200	253	313	127	98,4	15,9 x 4	150	110	18 x 4
50	2"	225	200	253	313	152,4	120,6	19 x 4	165	125	18 x 4
65	2 1/2"	280	200	271	331	177,8	139,7	19 x 4	185	145	18 x 4
80	3"	280	200	271	331	190,5	152,4	19 x 4	200	160	18 x 8
100	4"	280	250	278	338	228,6	190,5	19 x 8	220	180	18 x 8
125	5"	400	250	298	358	254	215,9	22,2 x 8	250	210	18 x 8
150	6"	400	300	310	370	279,4	241,3	22,2 x 8	285	240	22 x 8
200	8"	400	350	338	398	342,9	298,4	22,2 x 8	340	295	22 x 12
250	10"	500	450	362	422	406,4	361,9	25,4 x 12	395	350	22 x 12
300	12"	500	500	425	485	482,6	431,8	25,4 x 12	445	400	22 x 12
350	14"	500	550	450	510	533,4	476,2	28,6 x 12	505	460	22 x 16
400	16"	600	600	475	535	596,9	539,7	28,6 x 16	565	515	26 x 16
450	18"	600	---	500	560	635,0	577,8	31,7 x 16	615	565	26 x 20
500	20"	600	---	525	585	698,5	635,0	31,7 x 20	670	620	26 x 20
550	22"	600	---	550	610	749,3	692,1	34,9 x 20	---	---	---
600	24"	600	---	588	648	812,8	749,3	34,9 x 20	780	725	30 x 20
Standard											
with ANSI-flanges		from 1/2" – 24"			150 lbs						
with DIN flanges		from DN 15 – 200			PN 16						
		from DN 250 – 600			PN 10						
* Standard		**ISO 13359									



8.2 Amplifier type B-MAG I M5000

Technical data	
Type	B-MAG I M5000
Power supply	Internal Lithium batteries 3,6 V or 100-240 VAC or 9-36 VDC with battery back-up
Digital outputs	4 x open collector, passive 30 VDC/20 mA, max. 100 Hz
Low-flow detection	Separate electrode
Programming	3 keys
Interface communication	RS232, ModBus [®] RTU, IRDA, M-Bus, ADE AMR or GSM/GPRS module (optional)
Measuring range	0,03 – 12 m/s
Accuracy	±0,4% of m.v. ± 2 mm/s ±0,2% of m.v. ± 2 mm/s (special calibration)
Repeatability	0.1%
Flow direction	Bidirectional
Pulse width	Programmable up to 500 ms.
Low-flow cut off	0-10%
Display	LCD, 2 lines
Housing	Powder coated cast aluminium
Protection class	IP67 (IP68 optional)
Cable entry	Signal cable (outputs) M20
Signal cable	From detector M20
Ambient temperature	-20°C to 60°C

Dimensions
B-MAG I M5000

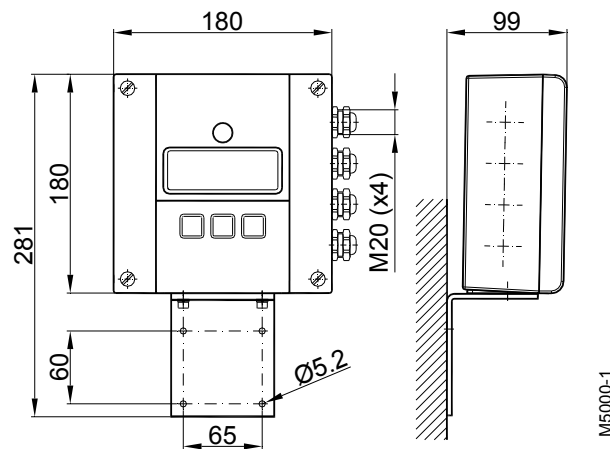

8.3 Error limits

Measuring range	:	0,03 m/s to 12 m/s
Pulse output	:	$\pm 0,4\%$ of m.v. ± 2 mm/s $\pm 0,2\%$ of m.v. ± 2 mm/s (special calibration)
Repeatability	:	$\pm 0,1\%$ of actual data

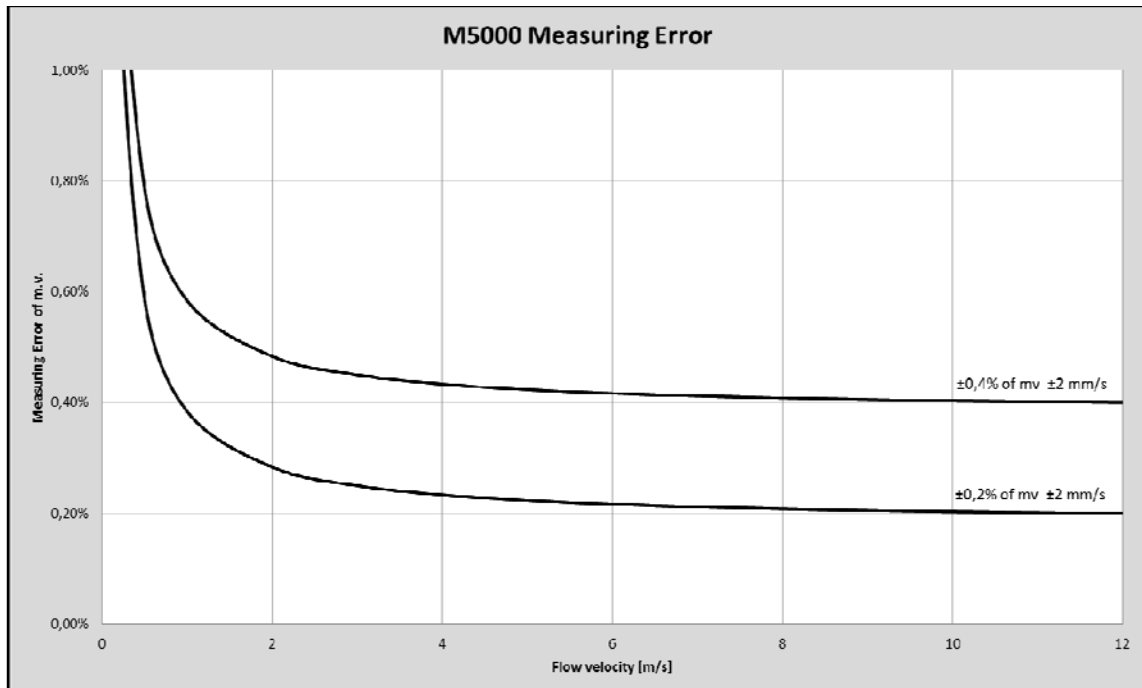

Reference conditions:

Ambient and fluid temperature	:	20°C
Electr. conductivity	:	> 300 μ S/cm
Warm-up period	:	60 min
Mounting conditions	:	> 10 DN inlet pipe > 5 DN outlet pipe Detector properly grounded and centered.



8.4 OIML approved meter

The B-MAG I M5000 is type approved according to the international water meter standards OIML R49. The meter is approved as Class I and Class II for the detector sizes DN 50 to DN 300.

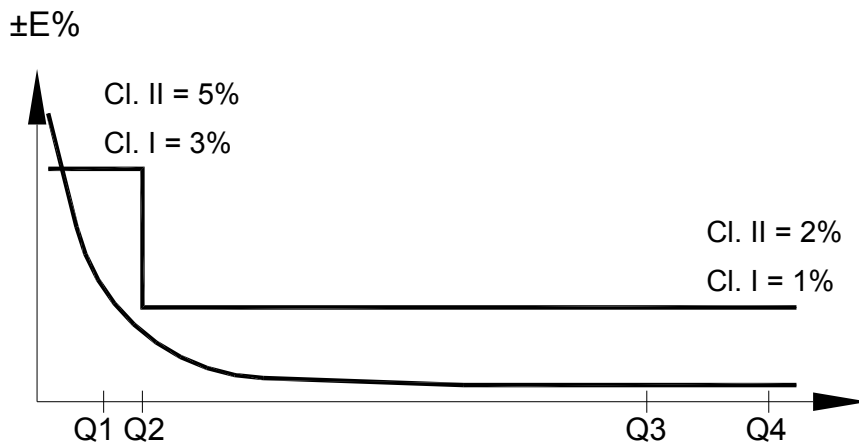

BA5000-28MID

Cl. I / II = OIML R49 Class I / Class II

$Q2/Q1 = 1,6$ and $Q4/Q3 = 1,25$

OIML R 49 specification for Class I

Size	50 2"	65 2 1/2"	80 3"	100 4"	125 5"	150 6"	200 8"	250 10"	300 12"
R (Q3/Q1)	200	200	200	250	250	160	160	160	160
Q1 [m³/h]	0,315	0,5	0,8	1	1,6	3,94	6,25	10	15,63
Q2 [m³/h]	0,504	0,8	1,28	1,6	2,56	6,3	10	16	25
Q3 [m³/h]	63	100	160	250	400	630	1000	1600	2500
Q4 [m³/h]	78,75	125	200	312,5	500	787,5	1250	2000	3125
OIML R49 Class	1								

OIML R 49 specification for Class II

Size	150 6"	200 8"
R (Q3/Q1)	250	250
Q1 [m³/h]	2,52	4
Q2 [m³/h]	4,03	6,4
Q3 [m³/h]	630	1000
Q4 [m³/h]	787,5	1250
OIML R49 Class	2	



8.5 MID approved meter (MI-001)

The B-MAG I M5000 is type approved according to Directive 2004/22/EC of the European Parliament and Council of March 31, 2004 Measuring Instruments (MID) Annex MI-001. The meter is approved for the detector sizes DN 50 to DN 300.

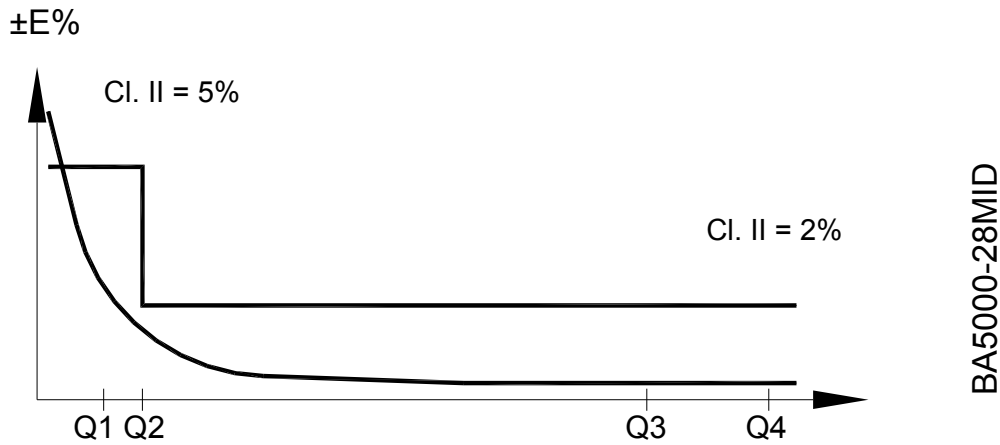

$Q2/Q1 = 1,6$ and $Q4/Q3 = 1,25$

Size	50 2"	65 2 1/2"	80 3"	100 4"	125 5"	150 6"	200 8"	250 10"	300 12"
R (Q3/Q1)	200	200	200	250	250	250	250	160	160
Q1 [m³/h]	0,315	0,5	0,8	1	1,6	2,52	4	10	15,63
Q2 [m³/h]	0,504	0,8	1,28	1,6	2,56	4,03	6,4	16	25
Q3 [m³/h]	63	100	160	250	400	630	1000	1600	2500
Q4 [m³/h]	78,75	125	200	312,5	500	787,5	1250	2000	3125

The conformity declaration of above certificate is according to module B (type approval) and D (quality insurance of production).



8.6 Size selection

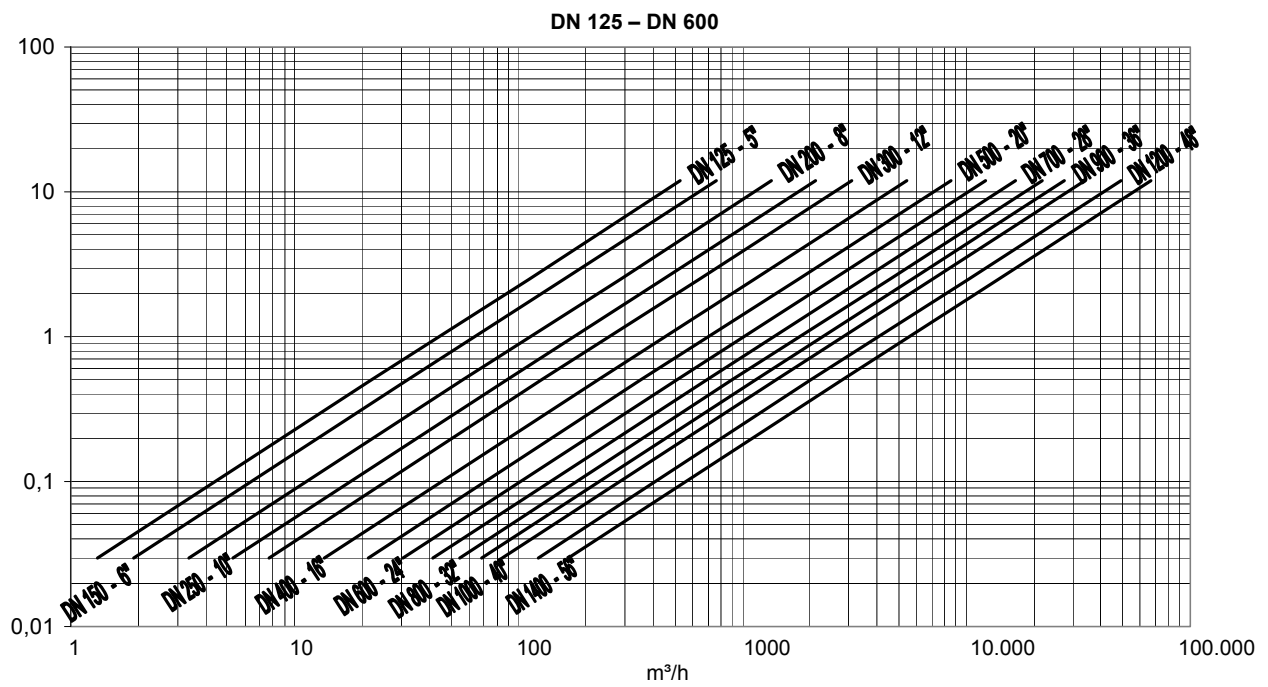
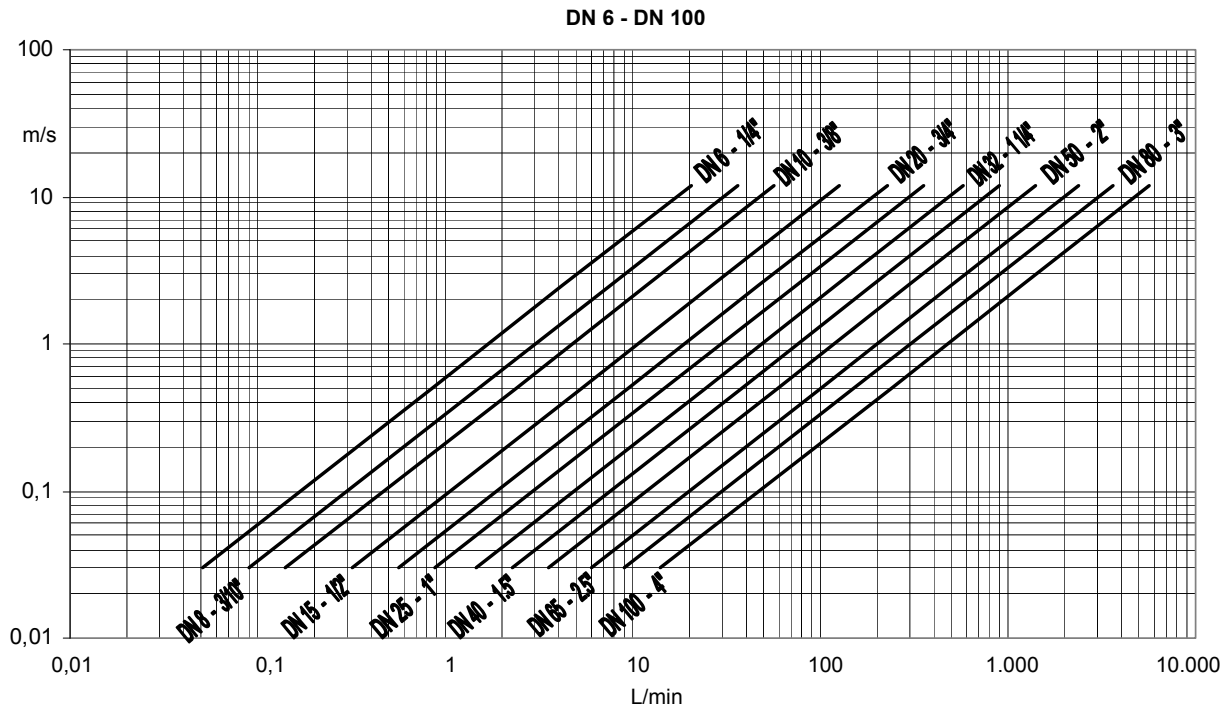

9. Program structure

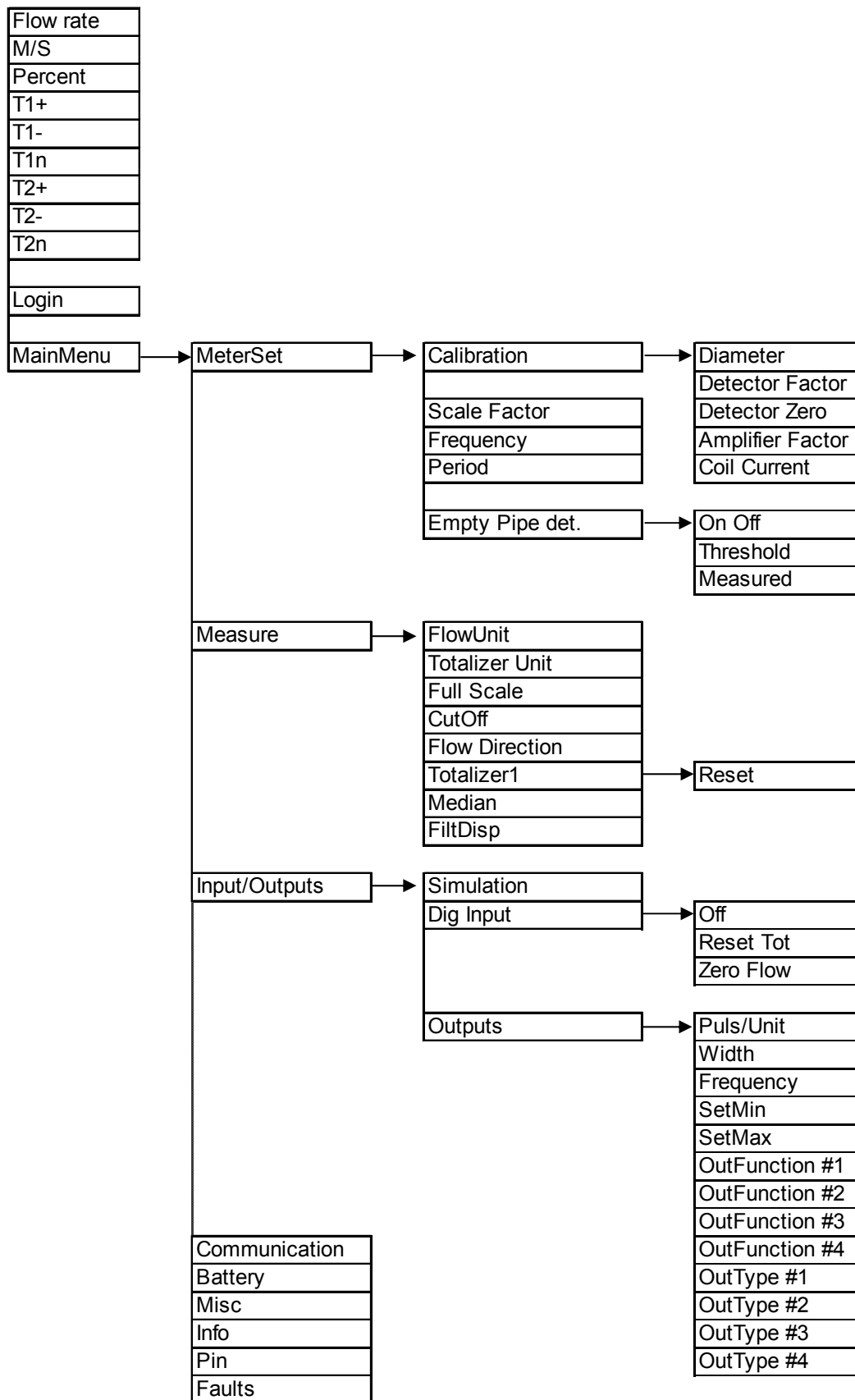

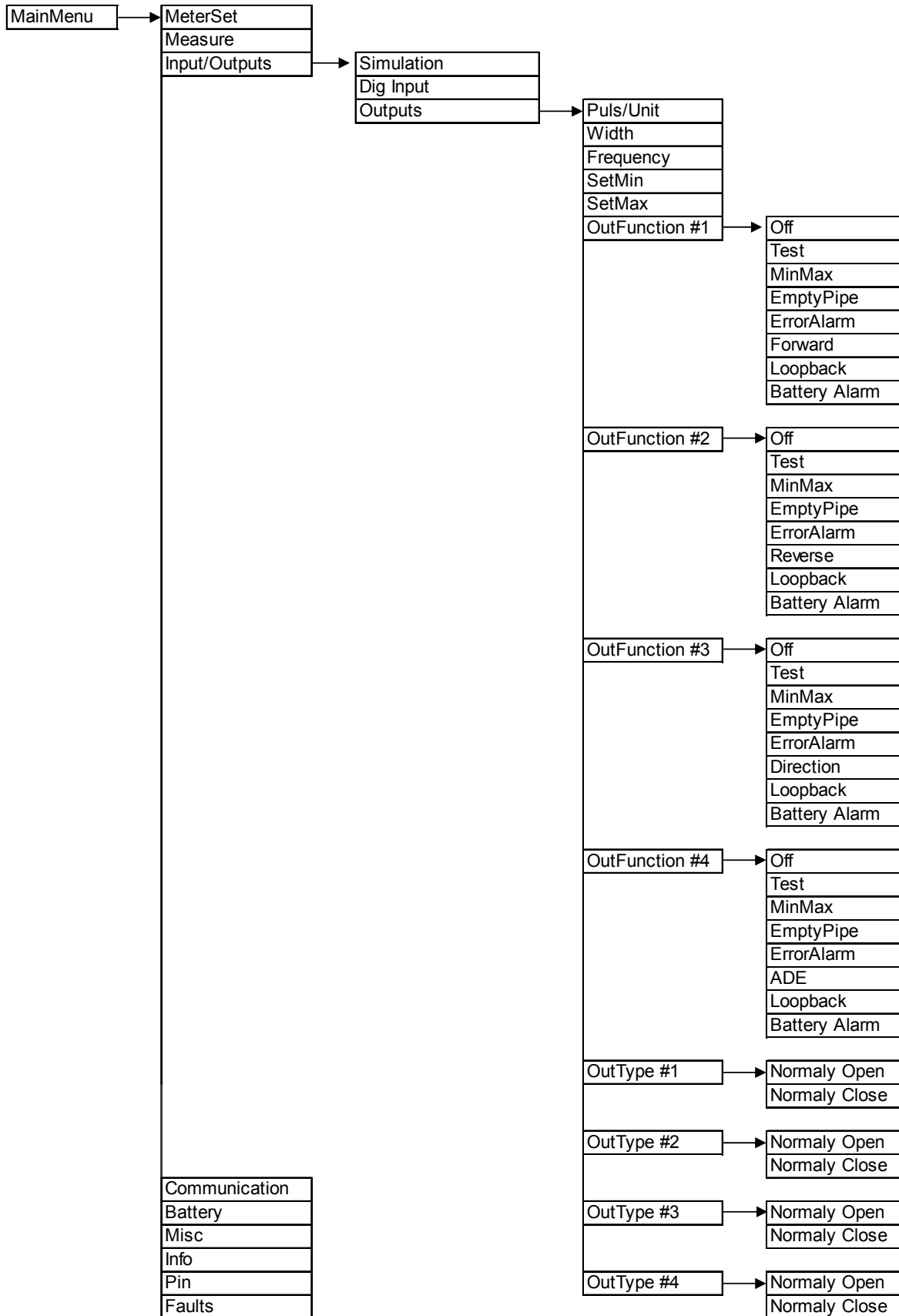

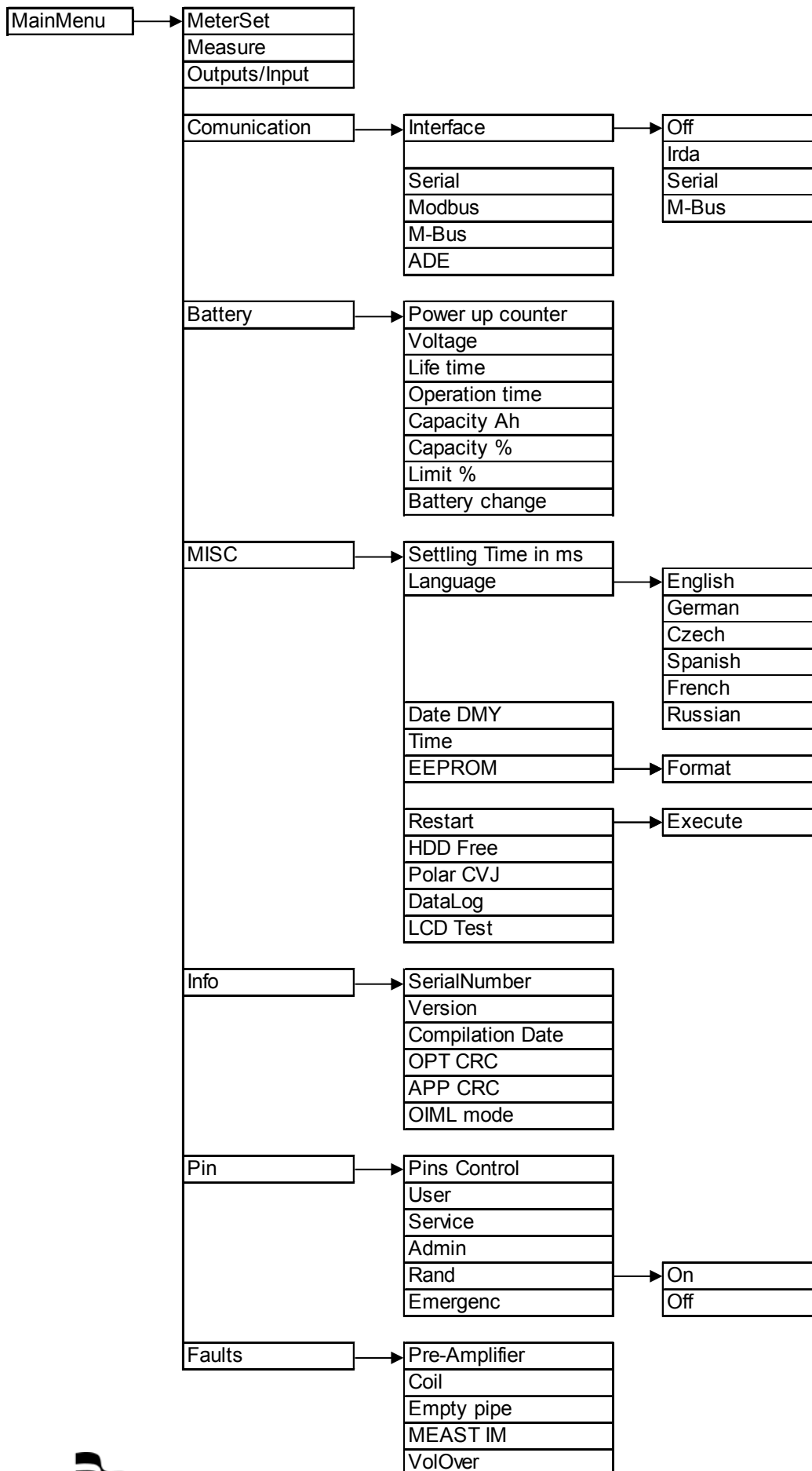

10. Spare parts

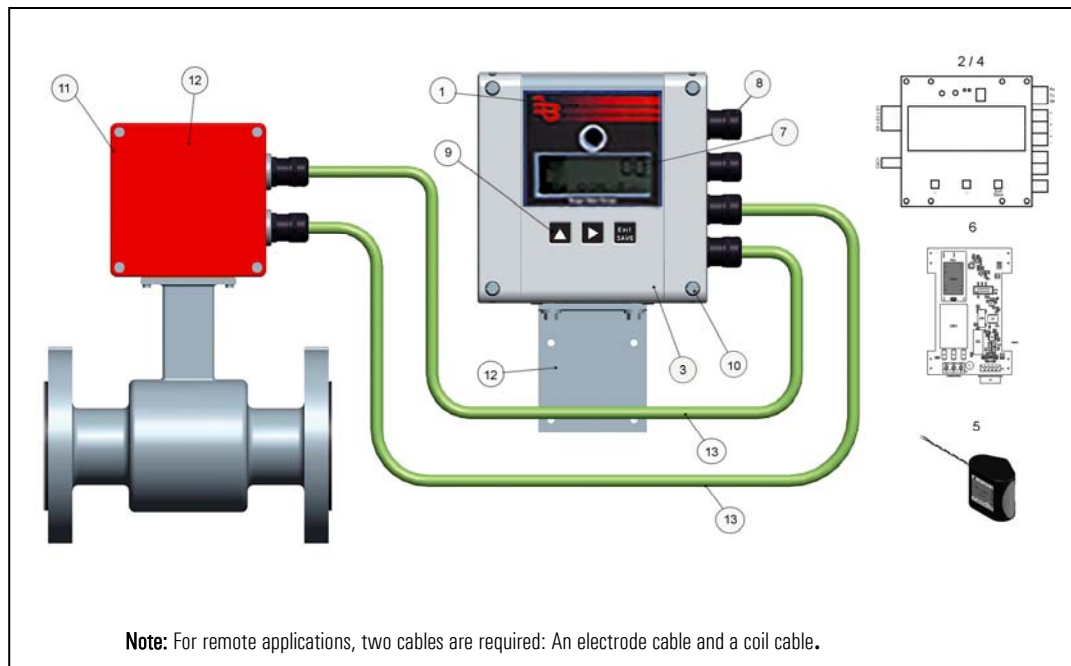

Pos.	Description	Part n°
1	Amplifier assembly complete	
	Complete without Batteries	592603
	Complete with 2 D-cells	592600
	Complete with 4 D-cells	592601
2	Board with M-Bus	384748
	Board with RS485	384759
3	Housing	384735
4	LCD display (only available with board)	
5	Battery pack 2 D-cells	384776
	Battery pack 4 D-cells	384777
6	Battery back-up board AC	384701
	Battery back-up board DC	384741
7	Display window	384709
8	Cable gland	384732
9	Buttons kit black	384707
10	Housing screws	384607
11	IP68 kit for remote version	383077
12	Remote mounting kit less cable	384870
	Remote mounting kit with cable	
	5 m	384871
	10 m	384872
	15 m	384873
	20 m	384874
13	25 m	384875
	30 m	384876
14	PC programming kit via USB/RS232	592604
	PC programming kit via IrDA	592605



11. Return of goods for repair

Please revert to the form under: www.badgermeter.de/service/return-of-goods.



Hotline

Tel. +49-7025-9208-0 or -30

Fax +49-7025-9208-15



Badger Meter Europa GmbH

Subsidiary of Badger Meter, Inc., USA

Nürtinger Strasse 76

72639 Neuffen (Germany)

E-mail: badger@badgermeter.de

www.badgermeter.de